Valid for:

L2X Drop-in systems

L2X Drop-in valve gate systems



L2X Drop-in hot runner system

Operating manual

1.	General remarks	7
1.1	Information on this operating manual	7
1.2	Manufacturer	7
1.3	Formal information on the operating manual	7
1.4	Conventions	8
1.4.1	Instructions and system responses	8
1.4.2	Enumerations	8
1.4.3	Abbreviations	8
2.	Safety instructions	9
2.1	Safety instructions and symbols used	9
2.1.1	Signal words for hazard classification	10
2.1.2	Explanation of pictograms	10
2.2	Intended use	11
2.3	Improper use	11
2.4	Qualification of staff	11
2.4.1	Demands on specialised staff	11
2.5	Personal Protective Equipment (PPE)	12
2.5.1	Symbols of the personal protective equipment	12
2.6	General hazards and safety measures	12
2.7	Electrical equipment	14
2.8	Spare and wear parts, auxiliary and operating materials	14
2.9	Limitation of liability	14
2.10	Warranty terms	15
2.11	Standards and directives	15
3.	Technical data	16
3.1	Mechanical specifications	16
3.1.1	Main dimensions of the HPS III hot runner system	16
3.1.2	Operating parameters of the HPS III hot runner system	16
3.2	Electrical specifications	16
3.2.1	Connections/connector pin assignment	16
3.3	Hydraulic / pneumatic specifications (drive units)	16
3.4	Operating conditions	16
3.4.1	Noise emission	16
3.4.2	Cooling agent	17
3.5	Type plate	17
4.	Functional description of the HPS III hot runner system	18

5.	Installation	20
5.1	Transport	20
5.1.1	Safety information on transport	20
5.1.2	Recommended lifting accessories and slings	21
5.1.3	Check the lifting accessories and slings before use	21
5.1.4	Attachment points	22
5.1.5	Working load limit for lifting accessories and slings	22
5.1.6	Removal from transport crate	24
5.1.7	Transport and movement during installation	24
5.2	General safety instructions	26
5.3	Technical Requirements	29
5.3.1	Tools and operating materials	29
5.3.2	Standard parts	32
5.4	Checks before installation	33
5.4.1	Notes on mould layout	33
5.4.2	Standard dimensions of hot runner systems	33
5.4.3	Dimensions to be checked for a L2X Drop-in hot runner system	34
5.5	Installation of L2X Drop-in hot runner systems	37
5.6	Electrical connection of hot runner systems	42
5.6.1	Safety instructions	42
5.6.2	General information	44
5.6.3	Wiring of 1-drop hot runner systems	48
5.6.4	Wiring of 2-drop hot runner systems	49
5.6.5	Wiring of 4-drop hot runner systems (manifold with 2 control zones)	50
5.6.6	Wiring of 6-drop hot runner systems (manifold with 2 control zones)	51
5.6.7	Wiring of 8-drop hot runner systems (manifold with 2 control zones)	52
5.6.8	Wiring of 8-drop hot runner systems (manifold with 4 control zones)	53
5.7	Checks after installation	54
6.	Start-up and instructions for operation	55
6.1	Safety instructions	55
6.2	Requirements for operation	57
6.3	Start-up of a HPS III hot runner system	58
6.3.1	First-time start-up and filling of a HPS III hot runner system	58
6.3.2	Start-up of an already filled HPS III hot runner system	58
6.3.3	Colour and material changes	58
6.4	Instructions for the operation of valve gate systems	60
6.4.1	Machine downtimes > 5 minutes of systems with HPS III-S / pro SHOT nozzles (system / single tip / single cavity)	61
6.4.2	Dismantling the mould after the end of production / dismantling the hot runner	61
6.5	Possible malfunctions	62
6.5.1	Troubleshooting	62

7. Maintenance	63
7.1 Safety instructions	63
7.2 Instructions for maintenance	63
7.3 Maintenance schedule	63
7.4 Checklist for possible maintenance work	64
7.5 Installation / deinstallation of nozzle tips	65
7.5.1 Safety instructions	65
7.5.2 General information	66
7.5.3 Versions of nozzle tips, nosepieces and screw-on gate bushes	67
7.5.4 Exchange of nozzle tips with nozzle installed in the mould	68
7.5.5 Exchange of nozzle tips outside the mould	68
7.5.6 Deinstallation of one-piece nozzle tips	69
7.5.7 Installation of one-piece nozzle tips	70
7.5.8 Deinstallation of two-piece nozzle tips	71
7.5.9 Installation of two-piece nozzle tips	72
7.6 L2X (valve gate) nozzles – exchange of thermocouple	73
7.7 Deinstallation / exchange of valve pins	76
7.7.1 Drive units with pistons - deinstallation und exchange of valve pins	76
7.7.2 Electric drive unit with step motor – deinstallation and exchange of valve pins	78
7.7.3 Electric drive unit with servo motor – deinstallation and exchange of valve pins	79
7.8 Instructions for service and repair	81
8. Decommissioning	82
8.1 Safety instructions	82
8.2 Instructions for disposal	83
9. Tightening torques	84
9.1 Tightening torques for socket head screws	84
9.2 Tightening torques for manifold screw connections and retaining screws	86
9.3 Tightening torques for tip inserts	87
9.4 Tightening torques for HPS III-L2X nozzles	89
9.5 Tightening torques for screws to fix the valve pin in the valve pin retainer	90
9.6 Tightening torques for drive units	90
9.7 Tightening torques for valve pin retainer for electric drive units	91
9.8 Tightening torques for valve pin seals	91
9.8.1 Tightening torques for one-piece valve pin seals	91
9.8.2 Tightening torques for two-piece valve pin seals	92

1. General remarks



NOTE!

Improper operation of the device may result in severe personal injury and considerable material damage! You must carefully read this operating manual and familiarise yourself with the safety installations before installing, commissioning or maintaining the device. Do not operate the device without having received appropriate training.

1.1 Information on this operating manual

This operating manual has been created in accordance with the directive 2006/42/EC to enable the safe and efficient operation of HPS III hot runner systems (hereinafter called hot runner system).

1.2 Manufacturer

EWIKON Heißkanalsysteme GmbH
Siegener Straße 35
35066 Frankenberg

Phone: +49 6451 501-0
Fax: +49 6451 501-202

E-mail: info@ewikon.com
Web: www.ewikon.com

1.3 Formal information on the operating manual

Person in charge of documentation: Henning Becker

Version: 3.0

Printing date: 10/07/2025

Language: German (original operating manual)

© Copyright, 2025

All rights reserved. Full or partial reproduction subject to prior written approval by EWIKON Heißkanalsysteme GmbH

1.4 Conventions

1.4.1 Instructions and system responses

Operating steps that have to be carried out by the operator are displayed as a numbered list. The sequence of the steps has to be adhered to.

Example:

1. Operating step 1
2. Operating step 2

1.4.2 Enumerations

Enumerations without mandatory sequence are displayed as a list with bullet points.

Example:

- Point 1
- Point 2

1.4.3 Abbreviations

The following terms and abbreviations are used in the operating manual:

Abbreviation	Meaning
PPE	Personal Protective Equipment
HPS	High Performance Systems
EU	European Union
BR	Installation space
H1	Manifold height
H2	Manifold height + top pressure pad
H3	Manifold height + pressure pad with centering + top pressure pad
H4	Manifold height + top pressure pad + bottom pressure pad
P	Height of nozzle retainer frame plate
B	Height of top pressure pad
KH	Nozzle body height
X	Nozzle length (lower edge of nozzle body to article surface)
ΔS	Gap dimension Delta S
R_A	Sprue bush radius
R_M	Machine nozzle radius
N	Height of hold-down device
HR	Retainer ring height
G	Height from centre axis of tip to end of nozzle
X	X dimension of nozzle
$T_{K1} / T_{K2} / T_{K3}$	Standard dimensions to determine gap dimension
G	Thread
P	Fit
SW	Width across flats
T	Blueing area

Abbreviation	Meaning
m	Mass
ρ	Density
V	Volume
L x B x H	Length x width x height (e.g. mould plate, hot half)
F	Force
M	Bending moment
T_{HK}	Hot runner temperature (processing temperature)
T_{WZ}	Mould temperature
ΔT	Difference $T_{HK} - T_{WZ}$

Chart 1: Terms and abbreviations

2. Safety instructions

The HPS III hot runner system conforms to the machinery directive 2006/42/EG and has been designed, manufactured and checked for safety according to the applicable safety rules and legislation and the state of the art.

The HPS III hot runner system is delivered in perfect working order.

The HPS III hot runner system may pose risks, if it is:

- not operated by professionally trained staff.
- used improperly or not used as intended.
- not in perfect order regarding safety.

2.1 Safety instructions and symbols used

Signal words introduce the safety instructions and are marked by symbols. They draw the user's attention to possible hazardous situations that may occur during installation, operation and maintenance. Safety instructions must be followed to prevent accidents, personal injury or material damage.

Warnings

- Protect against possible personal injury and material damage when followed
- Classify the extent of hazard by the signal word
- Indicate the risk of personal injury by hazard signs
- Indicate the type and source of hazard
- Indicate the risk and possible consequences
- Show measures to prevent hazards and prohibit certain behaviours



WARNING! = signal word

Source of hazard

Possible consequences, if ignored.

- Measures/prohibitions.

The hazard sign marks warnings which warn against personal injuries.

Source of hazard

The source of hazard indicates the cause of hazard.

Possible consequences, if ignored

If the warnings are ignored, possible consequences are e. g. crushing, burnings or other severe injuries.

Measures/Prohibitions

"Measures/Prohibitions" lists actions that are to be carried out to prevent a hazard (e. g. stop a drive unit) or that are prohibited to prevent a hazard.

2.1.1 Signal words for hazard classification



HAZARD!

indicates an imminently hazardous situation which, if not avoided, will result in death or serious injury.



WARNING!

indicates a potentially hazardous situation which, if not avoided, will result in death or serious injury.



CAUTION!

indicates a potentially hazardous situation which, if not avoided, will result in minor injury or material damage.



NOTE!

indicates useful additional information and tips to promote trouble-free operation and to prevent material damage

2.1.2 Explanation of pictograms



Read operating manual



Caution!
Risk of electrocution



Caution!
Hot surface



Caution!
Oxidising agents



Caution!
Suspended loads



Caution!
Risk of crushing



Caution!
Explosive atmosphere



Caution!
Hand injuries or cuts



Caution!
Pressurised systems



Caution!
Forklift trucks operating

2.2 Intended use

EWIKON hot runner systems are exclusively designed for the intended use described in this manual.

Any different and unintended use is excluded and may result in personal injuries and material damage. Warranty expires in this case.

EWIKON hot runner systems and single nozzles are only to be used for injection moulding applications, assembled in an enclosed injection mould.

They are used to process thermoplastic resins according to their individual processing requirements and to pass them gently from the injection unit to the cavity by optimum temperature distribution and flow paths.

In order to use the hot runner system as intended it is essential that all tips and information given in this operating manual are read, understood and followed.

To ensure safe operation of the hot runner system, the given maintenance & inspection schedule has to be adhered to.

The system is designed for an injection pressure of 2000 bar.

The resin used has to be processed according to the guidelines of the material manufacturer.



Use of the HPS III hot runner system

Use the HPS III exclusively for its intended use and in perfect condition as regards safety! This is the only way to guarantee a reliable operation of the HPS III hot runner system.

2.3 Improper use

Any use deviating from the use defined under "Intended use" or that goes beyond that use is considered improper use.

2.4 Qualification of staff

The staff has to prove that it is qualified to perform assembly, maintenance and repair. Any lack of knowledge has to be eliminated by training and briefing the staff.

2.4.1 Demands on specialised staff

Improper use of EWIKON hot runner systems may result in personal injuries or material damage. Only specialised staff is allowed to carry out any work.

Only specialised staff is allowed to install and operate EWIKON hot runner systems. Specialised staff is trained, has proven knowledge and experience in operating e. g. injection moulding units or electrical machines and devices as well as knowledge of the relevant regulations and is able to independently identify possible hazards and prevent them by taking protective measures.

2.5 Personal Protective Equipment (PPE)

Wear the necessary protective equipment when working on or near the machine. Special information on the personal protective equipment in the work area has to be observed.

2.5.1 Symbols of the personal protective equipment

Always wear the following when carrying out any work:



Protective clothes: To protect your body wear tight-fitting clothes with low resistance to tearing, without protruding parts and with long sleeves and long trousers. Do not wear rings, chains or any other jewelry.



Safety shoes: To protect yourself against electric shocks, melt splashes, heavy, falling objects and slips and falls on slippery surfaces.

Always wear the following when carrying out special work:



Safety glasses: To protect your eyes against scattering debris, heat and melt splashes.



Ear protection: To protect your ears against loud ambient noise.



Face mask: To protect your face against scattering debris, heat and melt splashes.



Protective helmet: To protect your head against falling objects and sharp edges.



Protective gloves (heat resistant): To protect your hands against extreme heat, abrasions, punctures and more severe injuries.



Heat resistant apron: To protect your body against extreme heat.

2.6 General hazards and safety measures

The company operating the system must comply with the statutory obligations on occupational safety. In addition to the safety instructions of this manual the safety, accident prevention and environment protection provisions applicable for the system's range of use must be adhered to. The operating company must clearly define responsibilities and make sure that all staff operating the system has read and understood this manual. The company also has to inform about hazards at regular intervals. Personal protective equipment has to be made available to the staff. Maintenance intervals have to be respected.



Risk of physical injuries by high pressure or unexpected material leakage

- Unexpected material leakage may result in burns. There is a risk of serious injuries or death and/or damage to the hot runner.
- There is also a risk of burns, if water gets onto or into the hot runner. If the water reaches dangerously high temperatures, the metal housing may burst and cause serious injuries due to emerging water vapour or melting resins.



Safety measures

- Make sure the hot runner system heats up evenly. Particularly for large manifolds it may be necessary to switch on nozzle and sprue bush heaters simultaneously, but later than the manifold heaters.
- Make sure the nozzle tips and/or the gates are not blocked by solidified resin that has a higher melting point and that there is no humidity on the hot runner system, e.g. caused by a leaky temperature control circuit (please see chapter „6.3 Start-up of a HPS III hot runner system“).

**Risk of burns**

- Hot surfaces
Many components of the hot runner systems get very hot and may cause severe skin burns when being touched.
- Hot material (plastic melt)
Never touch material leaking from the nozzle/the mould/the hot runner or the material inlet. Even material that seems to be cooled down already may still be hot inside the core and cause burns.

Safety measures

- Please make sure you wear your personal protective equipment (PPE) when working near or on a hot runner system. Pay special attention to warnings indicating hot surfaces. All components have to be cooled down to ambient temperature before you start working. Exceptions to these rules are explicitly mentioned.

**Risk of electric shocks**

- Danger to life by electric shock.
Touching live surfaces may result in severe or even lethal injuries.
- Always keep water away from live components and the hot runner. There is a risk of short circuits!

Safety measures

- Electrical systems have to be disconnected from the mains and secured against being switched on again before any work is carried out. Only authorised electricians are allowed to carry out any work on electrical systems.
- All components have to be connected to a suitable power source according to the wiring diagrams and under consideration of the applicable local regulations. Injection moulding machine and hot runner systems have to be grounded.

**Risk of physical injuries by suspended/heavy loads**

- Only trained staff is authorised to operate lifting devices and forklift trucks. Proceed slowly and with care. Prevent the uncontrolled swinging of the loads (e. g. the manifold).

Safety measures

- Lifting devices and forklift trucks have to be designed to bear the weight and the size of the hot runner system/manifold. Make sure to use the marked lifting points.

**Risk of physical injuries by pressurised connecting lines
(e.g. air, hydraulics, water)**

- All supply lines for the medium supply of the hot runner and/or the hot runner system or the hot half have to be long enough to prevent any stress when the mould halves part. They must not be affected by moving parts of the mould or of the machine. Prevent the hoses from rubbing over the edges of the mould as they may be damaged because this might cause a spontaneous leakage of pressurised process media (pressurised air, hydraulic oil, water).

Safety measures

- Make sure you have depressurised all supply lines before carrying out any work.
Only skilled personnel is allowed to carry out work on the supply lines. Please wear your personal protective equipment (PPE).

**Risk of physical injuries by sharp edges and corners**

- Sharp edges and corners pose a risk of injury, possibly resulting in skin abrasions and cut injuries.

Safety measures

- Make sure you wear protective gloves when working near sharp edges and corners.
Proceed with care.
- Make sure the system is clean and free of burrs.

**Risk of physical injuries by crushing of extremities**

- There is a risk of injury when lifting heavy loads during assembly operations, possibly resulting in crushing of hand or other parts of the body.

Safety measures

- Wear protective gloves to prevent injuries while working around heavy loads.
- Make sure all body parts are kept away from the hazardous area while setting down heavy loads.

2.7 Electrical equipment

**HAZARD!****Residual voltage after activation**

Risk of death by electric shock and severe injuries caused by live components.

- Check for zero potential before performing any work!

Any work on electrical equipment must be carried out by qualified electricians. Always apply the 5 safety rules when working with electrical components:

- Disconnect from the mains
- Secure against reconnection (by activating the repair switch and installing a safety lock at the same time, if necessary)
- Verify that the installation is dead
- Carry out grounding and short circuiting
- Provide protection against adjacent live parts

Maintenance work must be carried out by qualified and trained staff or maintenance staff. Never use the HPS III hot runner system with faulty or inoperable electrical connections. In case of energy supply disruptions immediately switch off the HPS III hot runner system. The maintenance & inspection schedules regarding electrical components given by the manufacturers have to be adhered to. Check for damaged insulation at regular intervals.

2.8 Spare and wear parts, auxiliary and operating materials

The use of non-OEM spare and wear parts as well as auxiliary material may pose risks. Only use original parts or parts approved by EWIKON Heißkanalsysteme GmbH. Only use auxiliary and operating materials which are suitable for their intended use (compare chapter „5.3 Technical Requirements“).

2.9 Limitation of liability

All information and instructions given in this manual have been compiled in consideration of the applicable standards and regulations, state of the art as well as our know-how and experience.

EWIKON does not assume liability for any damage caused by:

- Non-observance of this manual
- Improper use
- Use of unskilled staff
- Unauthorised retrofitting or technical modifications
- Use of non-approved spare parts as well as inappropriate auxiliary and operating materials

The technical service provided verbally, in writing or on the basis of tests represents our best knowledge but is not binding and does not release you from carrying out additional tests on the products supplied by us regarding their suitability for the intended use.

The use of the products is beyond our control. Therefore, it is your own responsibility to ensure that the products meet your specific requirements. Nevertheless, should an issue of liability arise, all damage shall be limited to the value of the products supplied by EWIKON and used by you.

We guarantee the perfect quality of our products in accordance with our general terms and conditions of sale and payment as well as the extended warranty conditions.

These are available on our homepage www.ewikon.com.

The statutory provisions prevailing at the time of conclusion of the contract shall apply.

We reserve the right of technical alterations to develop our products and enhance their performance properties.

2.10 Warranty terms

For warranty conditions of cold and hot runner systems and components please refer to the terms and conditions of EWIKON.

2.11 Standards and directives

EWIKON hot runner systems conform to the following European directives:

- Machinery Directive 2006/42/EC
- Low Voltage Directive 2014/35/EU
- EN ISO 12100:2010 Safety of machinery -
General principles for design - Risk assessment and risk reduction
- EN 60204-1:2007-06 Safety of machinery -
Electrical equipment of machines - Part 1: General requirements

3. Technical data

3.1 Mechanical specifications

3.1.1 Main dimensions of the HPS III hot runner system

Description	Quantity/size (approx.)	Unit
Dimensions	See catalogue / PO-related documents	mm
Weight	See catalogue / PO-related documents	kg

Chart 2: Main dimensions of the HPS III hot runner system

3.1.2 Operating parameters of the HPS III hot runner system

Description	Quantity/size (approx.)	Unit
Maximum injection pressure	2000	bar
Maximum operating temperature	Depending on order	°C

Chart 3: Operating parameters of the HPS III hot runner system

3.2 Electrical specifications

3.2.1 Connections/connector pin assignment

Description	Quantity/size (approx.)	Unit
Voltage	230	V
Frequency	50	Hz

Chart 4: Electrical data (only valid within the EU)

3.3 Hydraulic / pneumatic specifications (drive units)

Description	Quantity/size (approx.)	Unit
Maximum hydraulic pressure (normal operation: 30 bar)	50	bar
Maximum pneumatic pressure (normal operation: 8 bar)	10	bar

Chart 5: Hydraulic / pneumatic data

3.4 Operating conditions

Operating conditions	Size (approx.)	Unit
Ambient temperature (maximum value)	40	°C
Ambient temperature (minimum value)	10	°C
Relative humidity during operation (no condensation!)	20 to 80	%

Chart 6: Operating conditions

3.4.1 Noise emission

Determining the sound power level of noise sources based on noise pressure measurements acc. to DIN EN ISO 3741

Operating conditions	Size (approx.)	Unit
Distance to device	*	mm
Noise pressure level (operation)	*	dB (A)

Chart 7: Noise emission

* Values can be determined only after the entire system has been started up.

3.4.2 Cooling agent

The use of unsuitable cooling agents may result in deposits and corrosion in the component to be cooled. This will negatively affect the functionality of the hot runner system. Components of the hot runner system may be damaged by a reduced cooling performance in the worst case. Cooling agents (water) have to satisfy the following minimum requirements:

- Cooling by tap water is not recommended since hard water can cause deposits and corrosion.
- The water has to be clear, colourless and odourless.
- It has to be free from any floating or suspended matters.
- A warranty on the resistance of components to be cooled against corrosion attacks cannot be given. However, the use of suitable cooling agents can considerably enhance this resistance.

3.5 Type plate

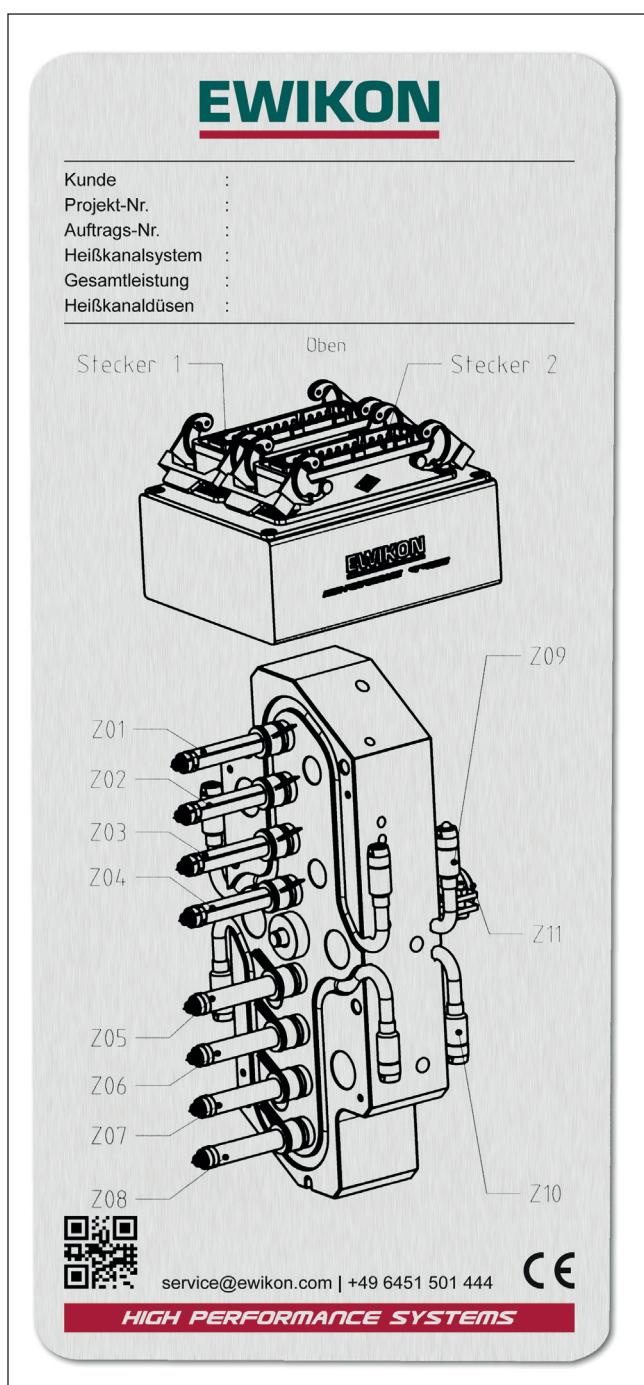

CAUTION!

Respect operating temperatures

Each hot runner system is individually designed for the material to be processed. Therefore, the specified operating temperatures must be observed. The temperature difference ΔT between hot runner temperature T_{HK} (processing temperature) and mould temperature T_{WZ} , must be strictly adhered to.

- Non-observance may cause an escape of melt inside the mould (ΔT too low) or damage to components (ΔT too large).

The system type plate is to be displayed prominently on the operator side of the mould. Hot halves are delivered with the type plate already mounted.

The type plate indicates project number, order number, type of hot runner system, overall performance, drive unit type, nozzles used and, if necessary, other important specifications.

For the exact allocation of heater zones and contact pins in the plugs please refer to the wiring scheme in the order specific documents.

Picture 1: Type plate

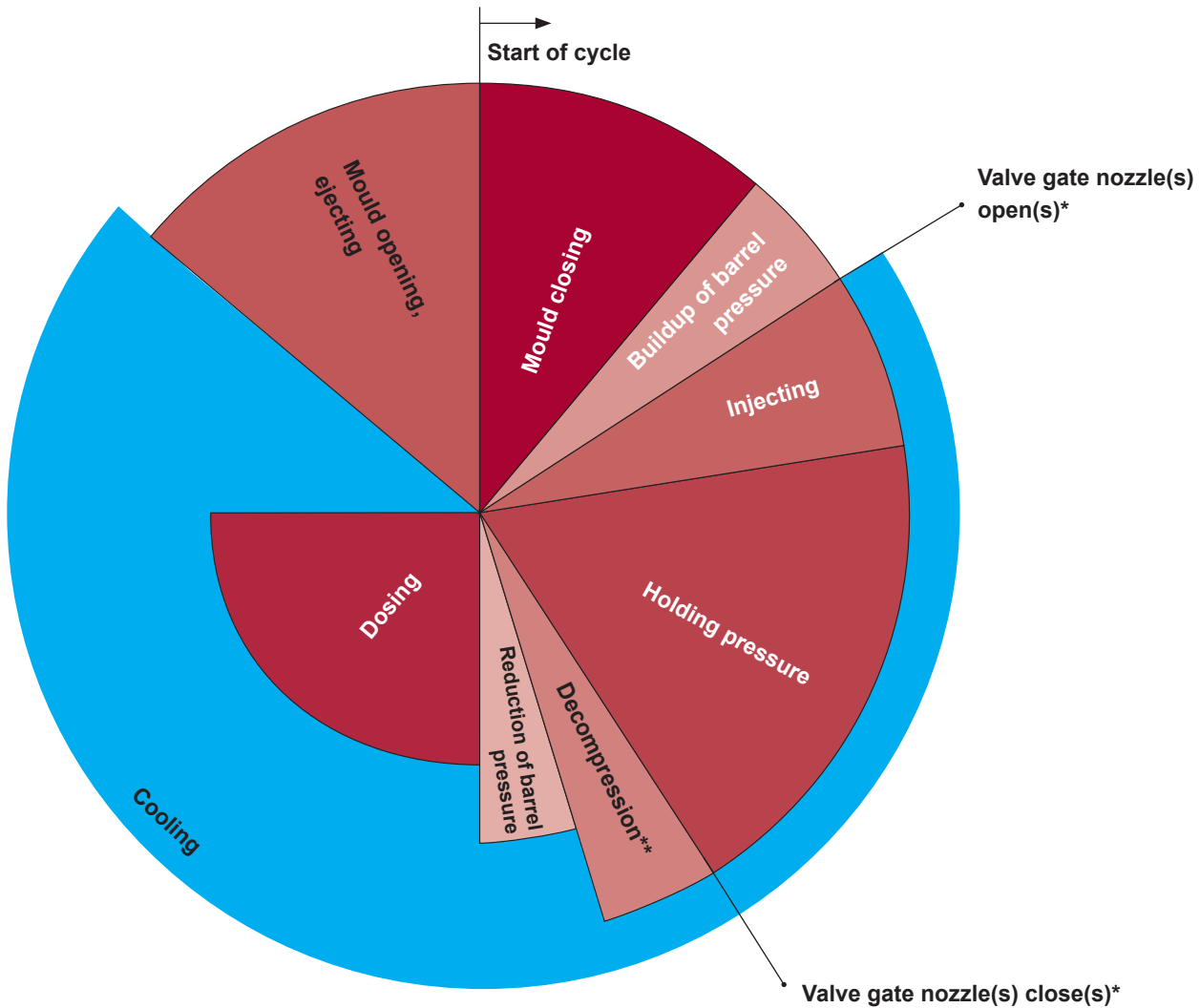

Picture 3: Injection moulding cycle

* for valve gate systems
 ** recommended for open systems

A hot runner system is used to distribute plastic melt between the injection moulding unit of an injection moulding machine and the cavities of an injection mould (compare picture 2). The plastic material remains permanently molten until it enters the cavities.

The plastic melt made available by the injection moulding unit is guided through the sprue bush to the manifold during the injection moulding cycle. In the manifold the melt stream for the individual cavities is split and fed to the hot runner nozzles. The hot runner nozzles guide the melt stream to the cooled cavities (compare picture 3).

If a valve gate system is used, the valve pins are opened when injection starts. While the moulded parts continue to cool down a holding pressure phase to compensate shrinkage follows after the injection phase with a continued, usually pressure-regulated melt transport into the cavity (compare picture 3). After the moulded part has solidified to such an extent that no new material can enter the cavity, the holding pressure phase has finished and the moulded parts cool down until they reach a safe demoulding temperature.

If a valve gate system is used the opening towards the cavity (gate) will be closed again by a movement of the valve pins after the holding pressure phase has been finished (compare picture 3). If open systems are used, a decompression phase will follow to prevent plastic melt from leaking from the gate area. While the moulded parts continue to cool down in the cavity the injection moulding machine can prepare the melt for the next cycle. After the demoulding temperature has been reached, the injection mould opens and the solidified parts are ejected.

5. Installation

The following information is intended to help you install the HPS III hot runner system. In addition, the assembly staff has to have the know-how required to install an HPS III hot runner system.

The described installation processes are examples for standard nozzles and standard systems. Special systems may require different procedures! Please observe the instructions in the order specific documents.

5.1 Transport

This chapter describes how to transport a hot runner system without damaging it and how to ensure occupational safety for the staff.

5.1.1 Safety information on transport



WARNING!

PPE

Suspended loads

Death and severe crushing of body or extremities.

- Keep clear of and do not pass under suspended loads.
- Keep clear of suspended loads while they are being transported.
- Do not touch lifting devices and lifting accessories while lifting the load.
- Only lift, transport and set down loads, if you have received appropriate training.
- Only use suitable and undamaged lifting devices and lifting accessories which are checked regularly.
- Do not exceed the maximum load limit of lifting accessories.



Sharp edges and heavy components

- Cut injuries to body and extremities, mainly to the hands.
- Crushing of fingers or hand.



NOTE!

Inappropriate transport

Damage to the HPS III hot runner system.

- Only specially trained staff is authorised to transport the HPS III hot runner system.
- Only use designated attachment points to attach lifting devices.
- Exercise greatest caution when transporting the HPS III hot runner system. Handle with care.

Pendular motion while lifting the hot runner systems with a lifting device (e.g. overhead crane)

Damage to the HPS III hot runner system and/or injection mould.

- Avoid pendular motions! Move HPS III hot runner system slowly and with care.
- When using the lifting device to connect heavy components avoid tilting while lifting and lowering.

5.1.2 Recommended lifting accessories and slings

The lifting accessories and slings have to conform to the machinery directive 2006/42/EC (i.a. the general principles section, chapter 4.1.2.5 "Lifting accessories and their components"). Forged steel components have to be checked according to DIN EN 1677-1 "Components for slings – Safety – Part 1: Forged steel components, Grade 8".

Please also see chapter „5.3.1 Tools and operating materials“.

Slings

- Attachment swivel (min. grade 8), swivelling 360° with self-aligning rotatable eye (180°).
Most current sizes used at EWIKON: M8, M10, M12 and M16. See Picture 4.

Lifting accessories which are required or admitted only for certain installation work:

- Lifting beam (for specifications please see suppliers of lifting beams). See PPicture 5.
- Spacer bolt for attachment swivel (allowed for L2X systems only, can only be purchased from EWIKON).
The spacer bolts must not be used for other transport processes! See PPicture 6. They should only be used when attachment swivels can not be used for lack of space.

Lifting accessories (to be used only with attachment swivels)

- Assembled chain slings according to DIN EN 1677 „Components for slings - Safety - Part 1: Forged steel components, Grade 8“ (with metal tag acc. to DIN 685). The octagonal red metal tags should show information about load capacities for usual modes of assembly (see PPicture 7).
- Webbing slings (see PPicture 8) and round slings (see PPicture 9) with sewn in label indicating the working load limit for common modes of assembly (for specifications see suppliers of webbing slings and round slings).

Overview of lifting accessories and slings:



Picture 4:
Attachment swivel

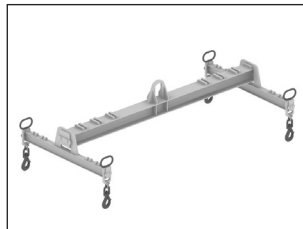

Picture 5:
Lifting beam

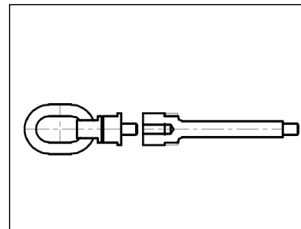

Picture 6: Spacer bolt for
attachment swivel



Picture 7:
Assembled chain sling



Picture 8:
Webbing sling

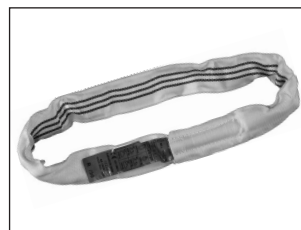

Picture 9:
Round sling

5.1.3 Check the lifting accessories and slings before use

- Lifting accessories and slings have to be checked regularly at intervals not exceeding 12 months by a qualified person. Inspection tags showing the expiration date of the current period of use should be attached directly to the lifting accessories and slings.
- A visual inspection of the lifting accessories and slings for damage has to be carried out before each use. As soon as the replacement state of wear, i.e. a defined wear characteristic, has been reached, the lifting accessories or slings must not be used any longer.
- Chains must not show any mechanical damage such as crushing, dents, deformations, expansions or cracks.
- Webbing slings must not show any yarn breaks, yarn cuts, damage to load bearing seams and deformations caused by heat or must not be subject to aggressive substances (acids, alcalis/bases, solvents).

5.1.4 Attachment points

Attachment points can be placed on the upside or on the side surfaces of the hot runner system or the hot runner component. Other possible attachment point positions are:

- Hot half (see Picture 10):
Upside (position A): used when removing the goods from the transport crate or on transport
Side surface (positions B and C): used on transport and installation
- Manifold (see Picture 11):
Upside (position A): when removing the goods from the transport crate or on installation
Side surface (position B): used when turning the manifold around
- L2X-System (see Picture 12):
Upside (position A): used when removing the goods from the transport crate oder on transport
Downside (position D): used on installation

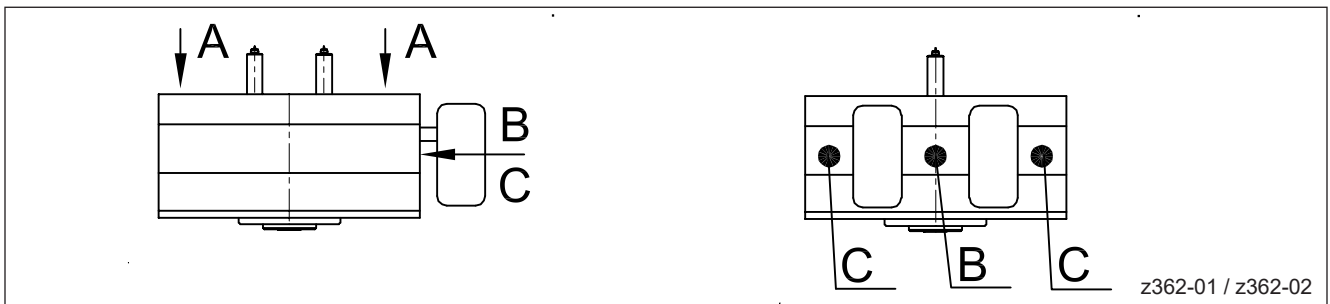

Picture 10: Possible attachment points to a hot half

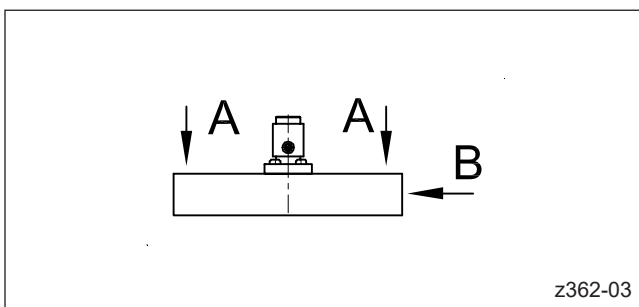

Picture 11: Possible attachment points to a manifold

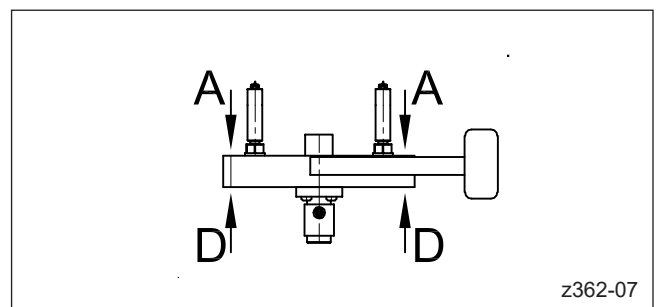

Picture 12: Possible attachment points to an L2X system

5.1.5 Working load limit for lifting accessories and slings

Before transport the working load limit for the used lifting accessories and slings must be checked in the following order:

1. How heavy is the load?

- The weight of single components, systems or hot halves is indicated on the EWIKON note of delivery (net weight, without packaging).
- If this information is not available anymore the weight can be estimated. However, there should be a sufficient margin up to the load limit of the lifting accessories and slings. The mass can be determined using the formula $m = \rho \cdot V$. Use the density of steel ($\rho = 7,85 \text{ g/cm}^3$) for your calculation. The calculated result automatically includes a sufficient safety margin because possibly existing hollow spaces or areas made of lighter materials are calculated using the density of steel. Calculate the volume of a hot half or a nozzle side with $V = L \times B \times H [\text{cm}^3]$. Possibly protruding areas (nozzles, wiring box) do not have to be taken into consideration. The volume of a manifold (without nozzles) or an L2X system (nozzles have already been screwed to the manifold) can be approached using the largest external dimensions of the manifold (L = largest linear expansion, B = largest width expansion, H = thickness of manifold).

2. Identify attachment points

- Where are the attachment points positioned (transport threads)?
- How many attachment points are available for specific transport situations?
- What are the thread sizes of the transport threads?

3. Is one single attachment point sufficient to lift the load vertically stretched or is more than one attachment point necessary to lift the load?

- Only for the transport of hot halves, nozzle sides or individual mould plates usually one single attachment point is sufficient (see Picture 13) as the gravity centre usually coincides with the attachment point! In this case the lifting capacity is 100 %. (see Chart 8)
- At least 2 attachment points are necessary to lift manifolds or L2X systems as otherwise it will not be possible to lift the load in a directed way. This is often absolutely necessary when carrying out installation work. When 2 attachment points are used to lift loads the following situations have to be distinguished:
 - The load is distributed between two evenly stressed but sloping legs (see Picture 14). The maximum load has to be reduced corresponding to the angle of inclination α (see Chart 8)
 - The load is distributed between two evenly stressed but vertically stretched legs (angle of inclination $\alpha = 0^\circ$) (see Picture 15). To apply force correctly the use of a lifting beam is absolutely necessary.
 - If the centre of gravity is asymmetric loads should be lifted using more than 2 attachment points. It can be helpful to use a lifting beam.
 - If spacer bolts for attachment swivels are used it is absolutely necessary to use a lifting beam to enable a correct application of force via vertically stretched legs (see Picture 16).
If the load is lifted using sloping legs, a force F will be generated causing a side load M in the screw-in thread. Breakage risk arises (see Picture 17).

4. Are the lifting accessories and slings approved for the respective modes of assembly?

- Is the allowed maximum weight respected?
- Is the load capacity reduced due to the specific lifting arrangement?

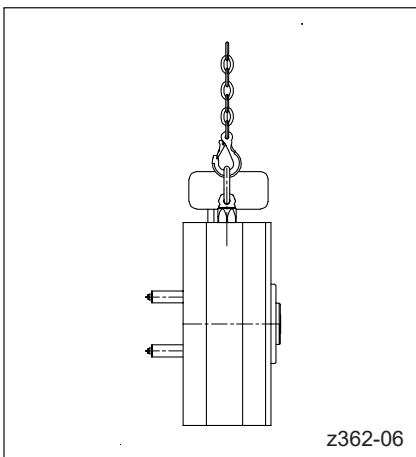

Picture 13: Lifting a load using one single attachment point (example: hot half in vertical position)

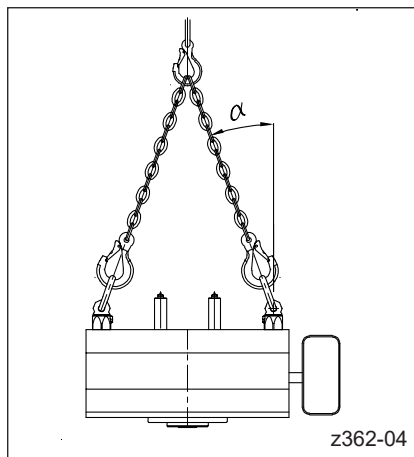

Picture 14: Lifting a load using 2 attachment points, distributed between two evenly stressed but sloping legs (example: hot half in horizontal position)

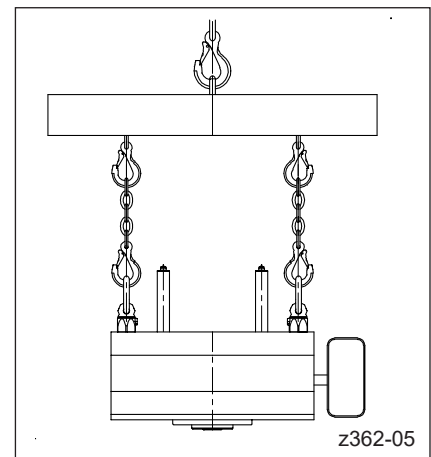

Picture 15: Lifting a load using 2 attachment points, distributed between two evenly stressed but vertically stretched legs (example: hot half in horizontal position)

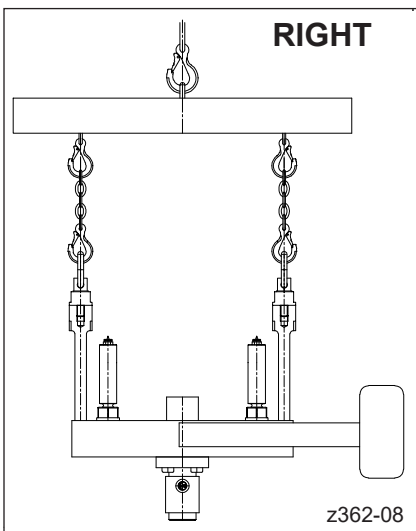

Picture 16: How to lift a load correctly using spacer bolts for attachment swivels (L2X system)

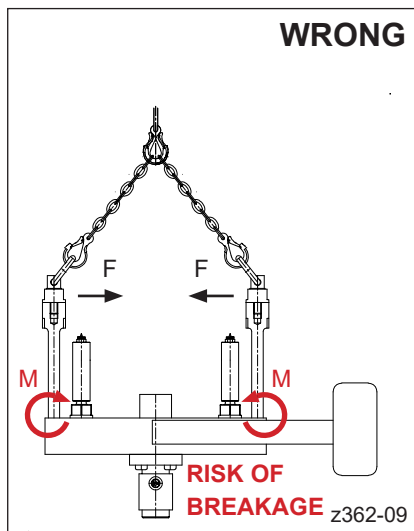

Picture 17: How to lift a load incorrectly using spacer bolts for attachment swivels (L2X system)

Angle of inclination	Load capacity of each leg of a 2-leg chain sling	Load capacity of the 2-leg chain sling
0 °	100 %	2 x 100 %
up to 45 °	70 %	2 x 70 %
45 ° up to 60 °	50 %	2 x 50 %
above 60 °	Use not permitted	

Chart 8: Assessment of stress of slings (source: BGI 556, for detailed information see above)

5.1.6 Removal from transport crate

How to remove a hot half, an L2X system or a manifold from a transport crate or a pallet (see Picture 14, Picture 15 and Picture 16).

- Open transport crate with suitable tools.
- Remove packaging material.
- Check hot half, L2X system or manifold for damage.
- Screw in attachment swivels and affix them to a crane (most products can be lifted out of the transport crate without having to remove the walls of the crate).
- Carefully lift hot half, L2X system or manifold vertically upwards and place it on a safe and non-slip surface (if system can be placed without damage) or on a safe substructure (e.g. for L2X system).

5.1.7 Transport and movement during installation



NOTE!

Consider reduced load capacity of attachment swivels!

For the installation work described below the attachment swivels are loaded at changing inclination angles. Depending on the manufacturer and design of the attachment swivel the maximum possible load capacity must no longer be utilized. If the attachment swivels recommended by EWIKON are used for such installation work (see chapter „5.1.2 Recommended lifting accessories and slings“), the maximum load capacity of an attachment swivel should always be reduced by at least the half.

Using wooden laths to move hot runner assemblies

- The surface to be used must be safe and non-slip.
- Height H of the wooden lath must only be high enough to enable a tilting of the hot runner assembly. Additionally, height H must be considerably smaller than width B ($H < B$) to prevent the hot runner assembly from slipping (see Picture 18).
- The contact surface L x B of the wooden lath must be large enough to prevent the hot runner assembly from slipping away while it is being moved. (see Picture 18).
- If possible the wooden lath should cover the whole length L of the hot runner assembly (see Picture 19).

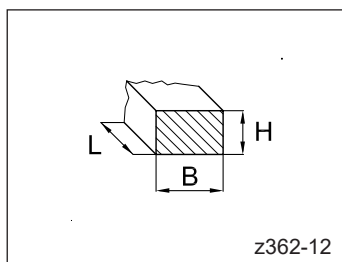

Picture 18: Dimensions of a wooden lath

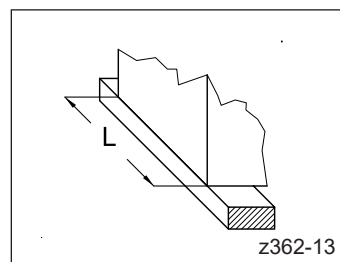

Picture 19: Positioning a hot runner assembly on a wooden lath

Putting hot runner assemblies (hot halves, mould plates, manifolds or L2X systems) from lying (horizontal) into upright (vertical) position.

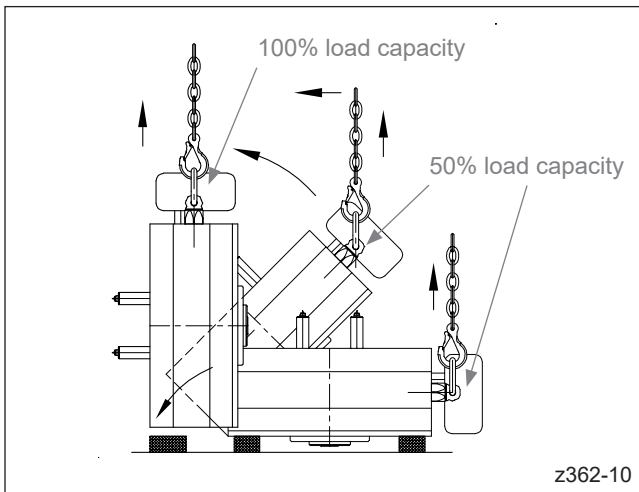

Picture 20: Putting hot runner assemblies (hot halves or mould plates or manifolds) from lying (horizontal) into upright (vertical) position

1. The hot runner assembly must be placed on an even, non-slip surface.
2. Screw in attachment swivels and affix them to a crane.
3. Put a wooden lath on the working surface and secure against slipping. It has to be positioned in such a way that when the external lateral surface of the hot runner assembly is erected it can be supported by the wooden lath.
4. Slowly lift the hot runner assembly until the lateral surface touches the wooden lath. Continue lifting the assembly until it reaches upright position following the movement of the hot runner assembly with the crane so that the crane hook is always perpendicular to the attachment point .
5. When the hot runner assembly hangs freely in upright position, remove the wooden lath and carefully place the hot runner assembly on a surface or move it using a crane.

Putting hot runner assemblies (hot halves, mould plates, manifolds or L2X systems) from upright (vertical) into lying (horizontal) position.

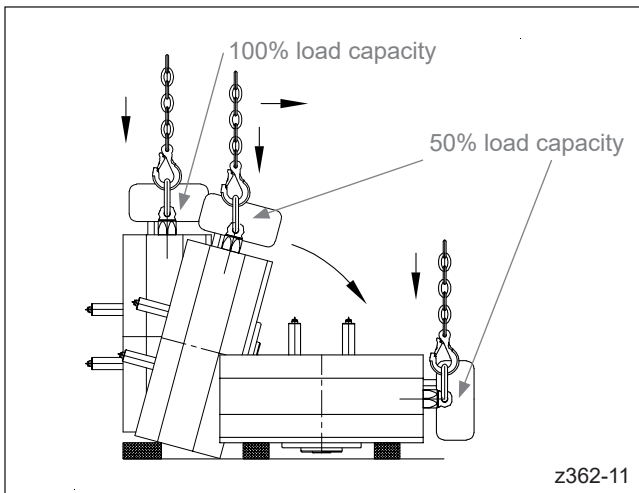

Picture 21: Putting hot runner assemblies (hot halves, mould plates or manifolds) from upright (vertical) into lying (horizontal) position.

1. Put a wooden lath on the working surface and secure against slipping. It has to be positioned in such a way that the external lateral surface of the hot runner assembly can rest on the wooden lath when it is dropped.
2. Use the crane to position the freely hanging hot runner assembly over the wooden lath
3. Slowly drop the hot runner assembly until the external lateral surface touches the wooden lath. Continue dropping the hot runner assembly carefully until it tilts and touches the working surface. Follow the tilting movement of the hot runner assembly with the crane so that the crane hook is always perpendicular to the attachment point.
4. Carefully put the hot runner assembly on the working surface following the movement of the hot runner assembly with the crane so that the crane hook is always perpendicular to the attachment point. Make sure there is a solid substructure so that protruding components are not damaged.



NOTE!

Pay attention to system characteristics

The work steps described just show how to move the system most commonly. Depending on the system layout further measures which have to be determined individually may be necessary to move and assemble hot runner assemblies in a safe way. The chapters „5.1.2 Recommended lifting accessories and slings“ and „5.1.5 Working load limit for lifting accessories and slings“ must be paid attention to.

- Particularly for L2X drop-in systems many system versions are possible. When any transport or assembly work is carried out it has to be ensured that protruding components (e.g. nozzles, heater outlets or wiring) as well as components with reduced stability (e.g. wiring channels, connection boxes or connection blocks for supply lines) are not damaged. It may be necessary to use additional lifting accessories and slings as well as specific substructures to support the hot runner assembly.
- A second crane may be necessary to turn the hot runner system completely to avoid accidents and damage to components.

5.2 General safety instructions



DANGER!

Installation with activated voltage supply

Risk of death by electric shock and severe injuries caused by live components.

- HPS III hot runner system, single tip nozzle, hot half and injection mould must be disconnected from the voltage source during installation.



WARNING!

Sharp edges and heavy components

- Cut injuries to body and extremities, mainly to the hands.
- Crushing of fingers or hand.



Hot surfaces

Body burns by hot surfaces.



Check of live components before installation

The electrical equipment of the hot runner system should be checked, especially those areas which will no longer be accessible after installation. Physical injuries such as an electric shock can be prevented that way.



Please check

- if cables are kinked or squeezed
- if cable insulations are undamaged.



Pressurized systems

All hydraulic or pneumatic supply lines must be depressurised during installation.

- Injuries caused by flying parts or "whipping" hoses.
- Injuries to eyes caused by escaping pressurised liquids.

PPE



**CAUTION!****Control of the given tolerances while checking important dimensions**

All given tolerances must be checked before initial installation. Failure to do so may result in leakage during operation, damage to nozzles and other components of the mould and severe injuries to persons such as burns caused by leaking plastic melt.

Machining the tip sealing area in the contour plate

The tip sealing areas should be ground or milled to fit but not eroded; otherwise leakage may be possible during operation.

Cleanliness of sealing surfaces

Prevent sealing surfaces from being damaged by dirt or unsuitable cleaning tools. Failure to do so may result in leakage during operation or damage to the sealing surfaces during installation.

**NOTE!****Intended use**

Damage to the HPS III hot runner system and/or components of the surrounding injection mould.

- The HPS III hot runner system must only be installed in a matching injection mould.

Recommended auxiliary materials (tools) and operating materials for the following installation steps

The use of non-approved assembly tools may result in damage to the hot runner system (for recommended auxiliary and operating materials please see chapter „5.3 Technical Requirements“).

Ambient conditions during installation

Make sure that the hot runner components are protected from direct humidity during assembly.

Dimensional check (for details please also see chapter „5.4 Checks before installation“)

Check of the given installation dimensions, fit sizes, form and location tolerances of the mould plates surrounding the hot runner system (for information please see the current catalogues in the download section on www.ewikon.com). The following dimensions have to be checked in particular:

- Mould plate dimensions.
- Height dimensions (e.g. X dimension).
- Fit sizes (e.g. in the tip sealing area).
- Gap dimensions.

Cleaning

- Clean the installation space.
- Make sure the sealing surfaces (contour plate/tip insert, nozzle/manifold) are clean. If necessary clean sealing surfaces with suitable cleaning tools (brass brush or brass scraper). Prevent sealing surfaces from being damaged by dirt or unsuitable cleaning tools. You have to heat up the HPS III-MH nozzles (processing temperatures) before cleaning them. Failure to do so may result in leakage during operation or damage to the sealing surfaces during installation.

Pay attention to temperatures during installation

The HPS III hot runner system has to be installed when it is cold (room temperature) (exception: L2X systems). Excessive temperatures during installation may result in damage to the melt sealing area and thus leakage during operation.

Mechanical stress of cable ends

The cable ends must not be subject to tensile stress.

Protect the cable ends

When wiring the system make sure that the thermo and power lines do not protrude from the outer edges of the mould and are protected against damage. The distances between hot runner and cables inside the mould have to be dimensioned in such a way that there is no damage to the components caused by excessive heat.

Secure the connection cables

All connecting cables have to be secured in such a way that they do not get pinched when they are installed in the mould (use cable binders and/or covering plates for the recesses).

Adhere to bending radii of the coil heater and the thermocouple when doing the wiring. The minimum bending radius is 15 mm. The connection can only be bent once.

Threads of screws and nozzle tips and threaded holes

Make sure all threads are clean and free moving, otherwise screws do not achieve the requested preload when tightened with the given torques. Screw connections may separate due to insufficient preload, possibly resulting in leakage during operation. When screwing in nozzle tips gaps between sealing surfaces may be possible - this may also lead to leakage during operation.

Unless otherwise indicated only use high-temperature lubricant (see chapter „5.3.1 Tools and operating materials“) to tighten threads in order to ensure the screws can be demounted any time.

Tightening torques

Wrongly chosen torques may lead to an excessive or insufficient preload of screws possibly resulting in leakage during operation due to separated screw connections (insufficient tightening torque) or damage to screws and associated components due to overload (excessive tightening torque).

When insufficient tightening torques are used to screw in nozzle tips gaps may form, when excessive tightening torques are used nozzle tips may be damaged. In both cases this may result in leakage during operation.

Customer-specific torque specifications in assembly drawings, e.g. for special designs, always have to be given priority over differing specifications.

Only the values summarised in this operating manual and in chapter „9. Tightening torques“ must be used. Also, please consider whether the tightening torques are valid for lubricated or non-lubricated screws.

5.3 Technical Requirements

Specific connections and hoses are used for supply lines (hydraulic, cooling water).

5.3.1 Tools and operating materials

Tool	Use	Version	EWIKON item no.
Abrasive paper / non-woven web	Exchange of nozzle heater	Various	-
Adjusting device pro EDGE VG (asm)	Installation of pro EDGE VG tip inserts	-	T00528-V01
Allen key	For hexagon socket head cap screw according to DIN EN ISO 4062	Depending on system and components. For wrench sizes see chapter „9. Tightening torques“.	-
Allen key, extension for allen key	Deinstallation of HPS III-MH clamping covers Deinstallation of a screw bush Exchange of seal kits of drive units Deinstallation / exchange of valve pins	Various	
Allen key with hole	Exchange of seal kits of drive units	Various	17919 19182
Blowtorch / small burner	Exchange of thermocouples	-	-
Cable markers (cable numbers)	Marking of electrical connections	-	-
Cable tie PA4.6	Fixation of cables, temperature sensors and shrink hoses	100 mm 150 mm	13590 13591
Calibration mandrel	Calibrating the rod seal	Various	See HPS III-NV catalogue
Calibration sleeve	Calibrating the piston seal	Various	See HPS III-NV catalogue
Centering aid	Assembly of L2X systems	Ø 10 mm/Ø 16 mm	19103/19104
Chain slings (with metal tag)	Lifting and moving of hot halves, systems (L2X) and plate assemblies	According to DIN EN 1677 (metal tag according to DIN 685)	-
Clamping device	Maintenance of HPS III-MHR nozzles	-	-
Cordless screwdriver	Exchange of valve pin seal of valve gate systems	-	-
Copper drift	Exchange of HPS III-MH thermocouples	-	-
Crimping tool	Attachment of cable pins to cables	-	-
Deduction aid pro EDGE VG (asm)	De- / installation of pro EDGE VG tip inserts	-	T00525-00
Depth gauge	Control of check dimensions	-	-
Disassembly sleeve	Deinstallation / exchange of valve pins	Various	See HPS III-NV catalogue
Drift punch	Installation of dowel pins	-	-
Engineers hammer	Maintenance work	-	-
Fabric tube	Protection of cables	Ø 6 mm	13479
Fixing ring pro EDGE VG	Assembly of pro EDGE VG tip inserts	-	T00544-V01
Handle for press-in mandrel	Manual assembly of the rod seal	-	T00663
Hexagon socket bit	Installation / deinstallation of HPS III-MH clamping covers. Installation with torque wrench only	Various	
Hexagon socket wrench insert	Installation / deinstallation of tip inserts. Installation with torque wrench only	Closed	-
Impact wrench	Deinstallation of a screw bush	1/2 inch adapter	-
Insertion sleeve	Assembly of the rod seal	Various	See HPS III-NV catalogue

Tool	Use	Version	EWIKON item no.
Installation wrench	Installation of drive units	Various	See HPS III-NV catalogue
Installation wrench, extension for installation wrench	for L2X nozzles	Various	See L2X catalogue
Insulation stripping pliers	Stripping of cables	-	-
Key with pilot	For hexagon socket screws according to DIN 6912	Key according to DIN 6911	-
Levering and striking tool	Disassembly of hot runner nozzles	Soft, preferably massive brass rod with tapered end, various sizes	-
Lifting beam	Lifting and moving of hot halves, systems (L2X) and plate assemblies	For specifications see manufacturer	-
Maintenance mouthpiece	Cleaning of flow channels		ask EWIKON
Maintenance set for drive seals	Replacing the drive seals	Various	See HPS III-NV catalogue
Mandrel	Installation of cable marker	-	-
Metal cable tie	Fixation of cables of L2X systems	-	19667
Multimeter	Measuring of resistance	-	-
Outside micrometre	Control of check dimensions	-	-
Oxy-acetylene burner	Deinstallation of a screw bush	-	-
Pin punch	Maintenance work	Various	-
Pipe wrench	Exchange of thermocouples	-	-
Press-in mandrel	Assembly of the rod seal	Various	See HPS III-NV catalogue
Protective jaws	Protection of hot runner component surfaces which are serviced in a vice outside the injection moulding machine	Material: aluminium	
Pull bar pro EDGE VG	De- / installation of pro EGDE VG tip inserts	-	T00524
Retaining flange pro EDGE VG	Disassembly of pro EDGE VG tip inserts	-	T00523
Ring end fitting	Installation / deinstallation of tip inserts. Installation with torque wrench only	Closed	-
Ring spanner insert	Exchange of HPS III-MH thermocouples	-	-
Ring wrench	Deinstallation of tip inserts	Closed	
Scraper, soft	Cleaning of e.g sealing surfaces	Preferably brass wire, do not use steel wire	-
Screw or threaded bar	Installation of HPS III-MH tip inserts; De- / installation of pro EDGE tip inserts	M4	-
Slotted screwdriver	Maintenance work	Various	-
Side cutter	Cutting cable binders to size without any risk of injury Removal of "cap" (see chapter „6.3.3 Colour and material changes“)	Preferably side cutter for electronics	
Snap ring pliers	Deinstallation of snap rings of drive units	-	-
Soft face hammer	Maintenance work	-	-
Spacer bolt for swivel eye bolt	Lifting and moving of hot halves, systems (L2X) and plate assemblies	-	19160
Spreading pliers	Installation of cable marker	-	-
Striking weight	Service and maintenance work	M10	10578

Tool	Use	Version	EWIKON item no.
Striking weight with forked adapter	Exchange of thermocouples	-	-
Swivel eye bolt	Lifting and moving of hot halves, systems (L2X) and plate assemblies	Swivel eye bolt according to Machinery directive 2006/42/EG or DIN EN 1677-1, min. grade 8 = 500 kg load capacity with inclination angle $\alpha = 0^\circ$. In case of deviations of the angle $\alpha > 0^\circ$ load capacity has to be reduced according to the manufacturers' instructions.	-
Thread adaptor	Deinstallation of a screw bush	M5	280016-15
Threaded rod for assembly	Assembly of pistons for drive units, Exchange of seal kits Deinstallation / exchange of valve pins	Various	See HPS III-NV catalogue
Toggle press	Assembly of the rod seal	-	-
Torque wrench (calibrated)	For even preload	4-400 Nm (3-295 ft-lb) depending on system and components	-
Torx screwdriver	Maintenance work	Various	-
Tubular hexagon spanner	Installation of valve pins	Various	See HPS III-NV catalogue
Vice	Maintenance work	-	-
Webbing slings and round slings	Lifting and moving of hot halves, systems (L2X) and plate assemblies	For specifications see manufacturer	-
Wire brush, soft	Cleaning of e.g sealing surfaces	Preferably brass wire, do not use brass-coated wire or steel wire	-
Operating material	Use	Version	EWIKON item no.
Engineers blue	Blueing of all surfaces where the manifold touches the mould.	Customary	-
High temperature (metal-compound) installation paste	Apply to all screw threads to ensure that the screws can be loosened/removed	Ciric A, Molyduval GmbH Collapsible tube (100g) Operation temperature up to 1200°C	17363
(Fully synthetic) High performance grease	Lubrication of components in injection moulds such as ejectors, sliders and guide pillars as well as all moving and sliding mould components. Lubrication of polymer seals for the assembly of pneumatic and hydraulic drive units.	VGS 180, Meusburger GmbH Dispenser 180 g Can 900 g Operation temperature up to 180°C	HB00002 HB00003
Heat transferring paste P12	For thermocouples	Collapsible tube (20 ml)	10023
Industrial adhesive	Gluing of guide bushes for synchronous plate systems into the synchronous plate	Loctite 648 HG , Henkel	-
Lubricating grease	Lubrication of the actuator drive shaft of electric servo drives	Klüberfood NH1 94-301	HB00052
Solid-free high-temperature grease	Lubrication of components of pro EDGE VG	VGI 300, Meusburger GmbH Can 20 g Application temperature up to 300°C	26095
WD 40 penetrating oil	Exchange of thermocouples	-	-

Chart 9: Auxiliary and operating material

5.3.2 Standard parts

**NOTE!****Only use approved standard parts**

Damage to the HPS III hot runner system and/or components of the surrounding injection mould.

- Only standard parts which are approved for operation in EWIKON hot runner systems must be used.

The following standard parts with the associated standards are approved for EWIKON hot runner systems. Particularly for screws the associated strength classes (see chapter 5.5 Assembly of the system / the components) and tightening torques (compare chapter „9. Tightening torques“) must be adhered to.

Standard part	Valid standard	Invalid/old standard
Hexagon socket head cap screw	DIN EN ISO 4762 (ISO 4762)	DIN 912
Hexagon socket head cap screw - low head, with pilot recess	DIN 6912	-
Countersunk screw	DIN EN ISO 10642 (ISO 10642)	DIN 7991
Parallel pin	DIN EN ISO 2338 (ISO 2338)	DIN 7
Parallel pin with internal thread	DIN EN ISO 8735 (ISO 8735)	DIN 7979
Flat washer	DIN EN ISO 7089 (ISO 7089)	DIN 125-1 (DIN 125)
Flat washer	DIN EN ISO 7092 (ISO 7092)	DIN 453-1 und DIN 433-2
Feather key	DIN EN ISO 773 (ISO 773)	-
Lock ring	DIN 471	-
Split pin	DIN EN ISO 8752 (ISO 8752)	DIN 1481

Chart 10: Approved standard parts for EWIKON hot runner systems

5.4 Checks before installation

The HPS III hot runner system is subject to comprehensive testing by the manufacturer before delivery. For safety reasons (transport or storage damage or damage to the hot runner system when preparing installation) we recommend that you check the hot runner systems for damage just before installing it. To exclude any damage during installation all information about checks which are part of this operating instructions must be adhered to.

5.4.1 Notes on mould layout

The following factors must be observed for the mould layout:

- Installation notes for the mould design
- Mould stability
- Sealing of the hot runner system
- Cooling
- Material
- Preload (calculation of gap dimension)
- Check of gate diameter



NOTE!

See the EWIKON HPS III catalogue, chapter 5 "General assembly notes", for a detailed description of general assembly notes and mould layout. The current version of the catalogue can be found on www.ewikon.com in the download section.

5.4.2 Standard dimensions of hot runner systems

All given installation dimensions, fit sizes, form and location tolerances of the mould plates surrounding the hot runner system have to be checked (for specifications please refer to the current catalogues on www.ewikon.com in the download section and/or the attached order-related documents). An overview of all relevant dimensions is given in Picture 22.

Particularly the following dimensions have to be checked:

- Check of the fit sizes in the tip sealing area / sealing collar of the tip insert and the installation contour of the mould plate.
- Height dimensions (X dimension, thickness of the clamping plate) have to be checked.
- Measuring of the mould plate: important for calculating the installation depth of the nozzle (X dimension)
- Thickness of the nozzle retainer frame plate (at at least 2 different ends of the plate)
- Installation depth for nozzle (from the contact surface of the nozzles to the top edge of the mould plate)
- Installation depth of pressure piece with centering (from the contact surface of the pressure pad until its top edge)
- Thickness of the manifold with screwed-in pressure pads H3 (from top side of pressure pad to nozzle sealing surface of the respective nozzle)
- Actual value of the gap dimension ΔS
- Thickness of the clamping plate. If pressure pads are installed in the clamping plate they also have to be measured and considered when calculating the gap dimension (special design).

This applies to systems with single nozzles in particular as only the locating ring fixes the single nozzle in the installation space. If there is a gap the injection pressure (pressure build-up around the cavity, if it is filled) causes the nozzle to move back to the locating ring, possibly resulting in leaks.

5.4.3 Dimensions to be checked for a L2X Drop-in hot runner system

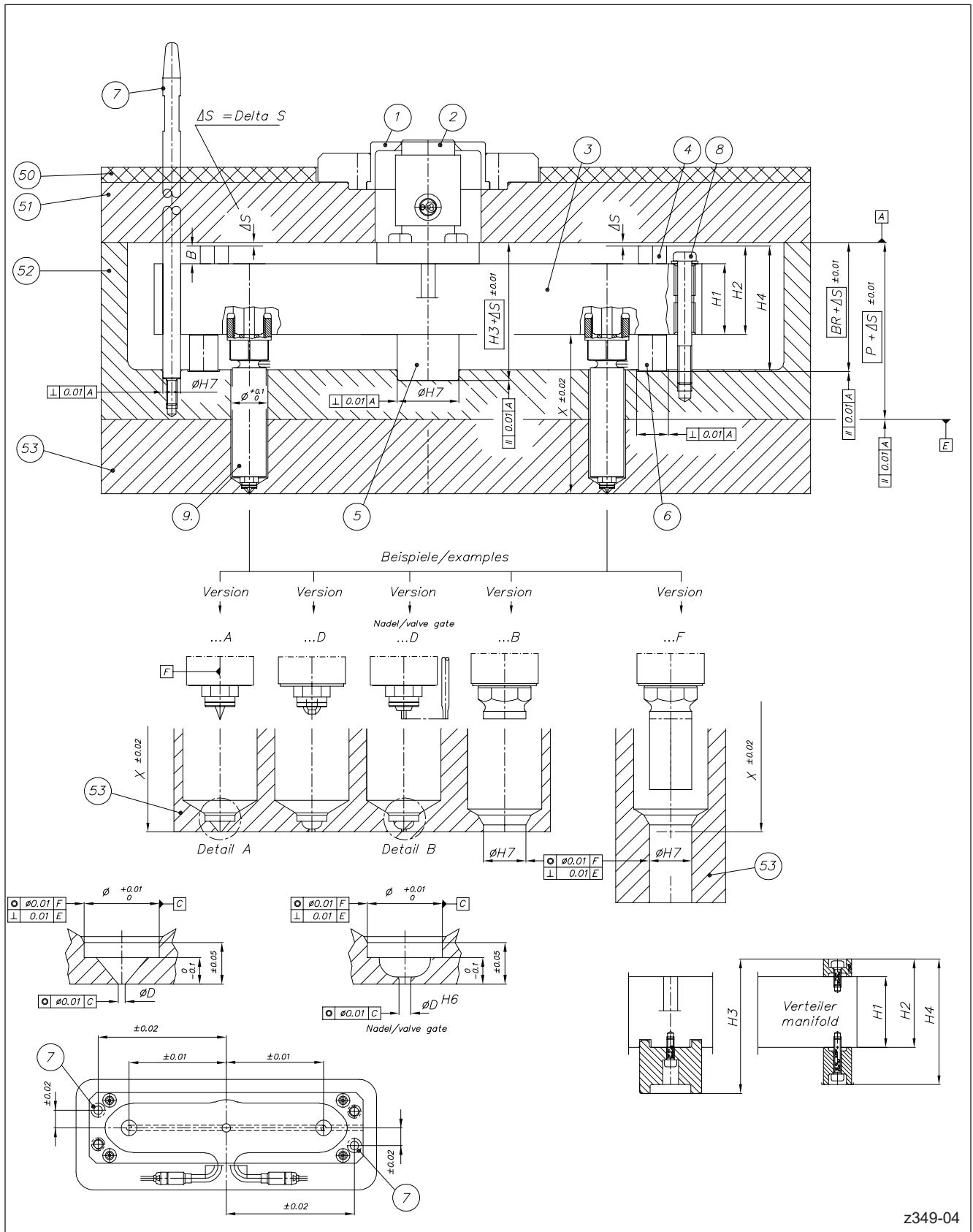

Picture 22: Example: Dimensions to be checked for a L2X Drop-in hot runner system

Example: Dimensions to be checked for a L2X Drop-in hot runner system

BR	Installation space (for EWIKON parts)	Pos. 1	Locating ring
H1	Manifold height	Pos. 2	Sprue bush
H2	Manifold height + top pressure pad	Pos. 3	Manifold
H3	Manifold height + pressure pad with centering + top pressure pad	Pos. 4	Top pressure pad
H4	Manifold height + top pressure pad + bottom pressure pad	Pos. 5	Pressure pad with centering
P	Height of nozzle retainer frame plate	Pos. 6	Bottom pressure pad
B	Height of top pressure pad	Pos. 7	Locating bolt (pre-centering, only for installation)
X	Nozzle length (lower edge of nozzle body to article surface)	Pos. 8	Screw connection for manifold
ΔS	Gap dimension delta S is achieved by: frame plate provided with allowance (pos. 52) as shown in the drawing (recommended by EWIKON) or grinding of the top pressure pads on the manifold.	Pos. 9	L2X nozzle
		Pos. 50	Insulating plate
		Pos. 51	Clamping plate (e.g. 1.2312) > 1000 N/mm ²
		Pos. 52	Nozzle retainer frame plate (e.g. 1.2312) > 1000 N/mm ²
		Pos. 53	Contour plate

5.5 Installation of L2X Drop-in hot runner systems

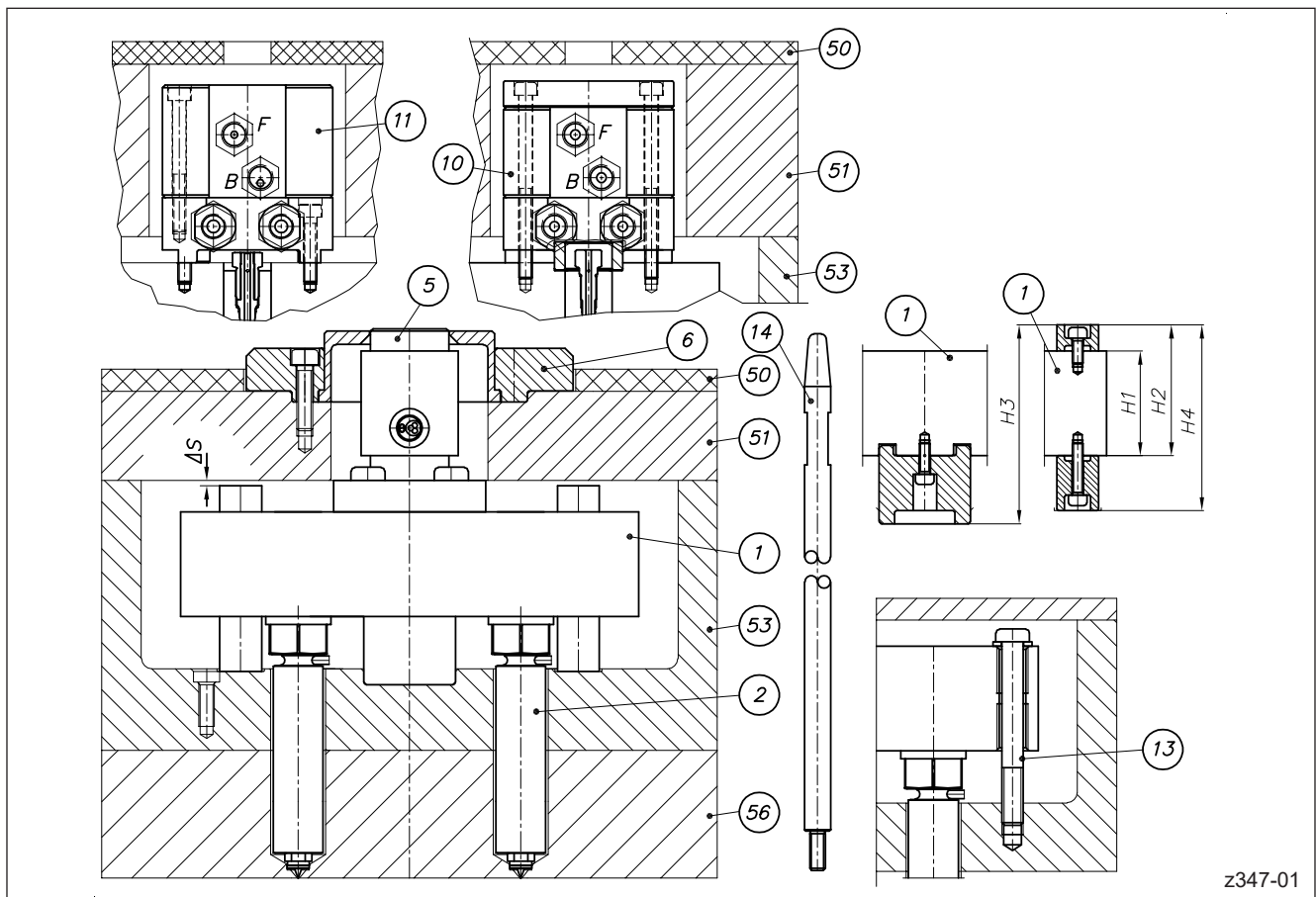

z347-01

Picture 23: General layout of a L2X system

- Pos. 1 Manifold
- Pos. 2 L2X nozzle
- Pos. 5 Sprue bush
- Pos. 6 Locating ring
- Pos. 10 Drive unit on manifold (screwed-on) (version 1)
(for valve gate systems)
- Pos. 10 Drive unit on manifold (screwed-on) (version 2)
(for valve gate systems)
- Pos. 13 Screw connection for manifold
- Pos. 14 Centring aid
- Pos. 50 Insulating plate
- Pos. 51 Clamping plate
- Pos. 53 Nozzle retainer frame plate
- Pos. 56 Contour plate

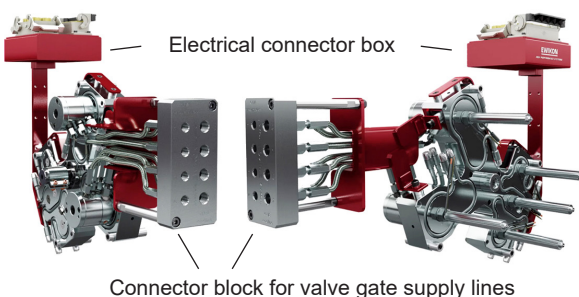

HPS-III-L2X-Heißkanalsystem_Montage_BA_V3_0_EN



NOTE!

Read operating manual

In the installation process described in the following hazards for the personal health are listed explicitly.

Furthermore, during installation the warning, safety and installation notes for installation of EWIKON hot runner systems and components as specified in chapter „5.2 General safety instructions“ must be followed!



NOTE!

Dimensional check

Before installation the installation dimensions as listed in chapter „5.4 Checks before installation“ must be checked and compared with the values provided with the installation drawing.

Use approved standard parts only

Only standard parts which are approved for use in EWIKON hot runner systems must be used. See chapter „5.3 Technical Requirements“.

The positions 1 - 2 are delivered as a completely assembled and wired system including electrical connector box. In addition the valve gate version includes the complete piping for the drive units as well as a connector block for the supply lines.

Introduction

The installation steps described in the following generally apply for L2X Drop-in hot runner systems for open gating as well as for valve gate systems. Any differences are explicitly mentioned in the describing text.

Preliminary measures

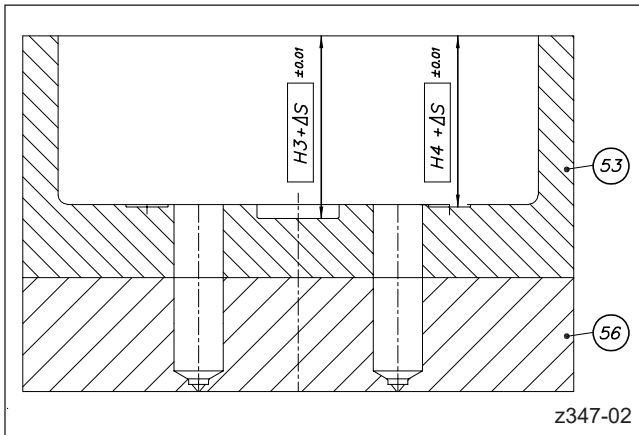

Picture 24: Check of reference dimensions

Dimensions to be checked:

Dimension $H3 + \Delta S$ between the upper surface of the nozzle retainer frame plate (pos. 53) and the contact surface for the centre support of the manifold.

Dimension $H4 + \Delta S$ between the upper surface of the nozzle retainer frame plate (pos. 53) and the contact surface of the pressure pads underneath the manifold.

Compare both dimensions to the values given in the drawing provided by EWIKON.

Preliminary measures

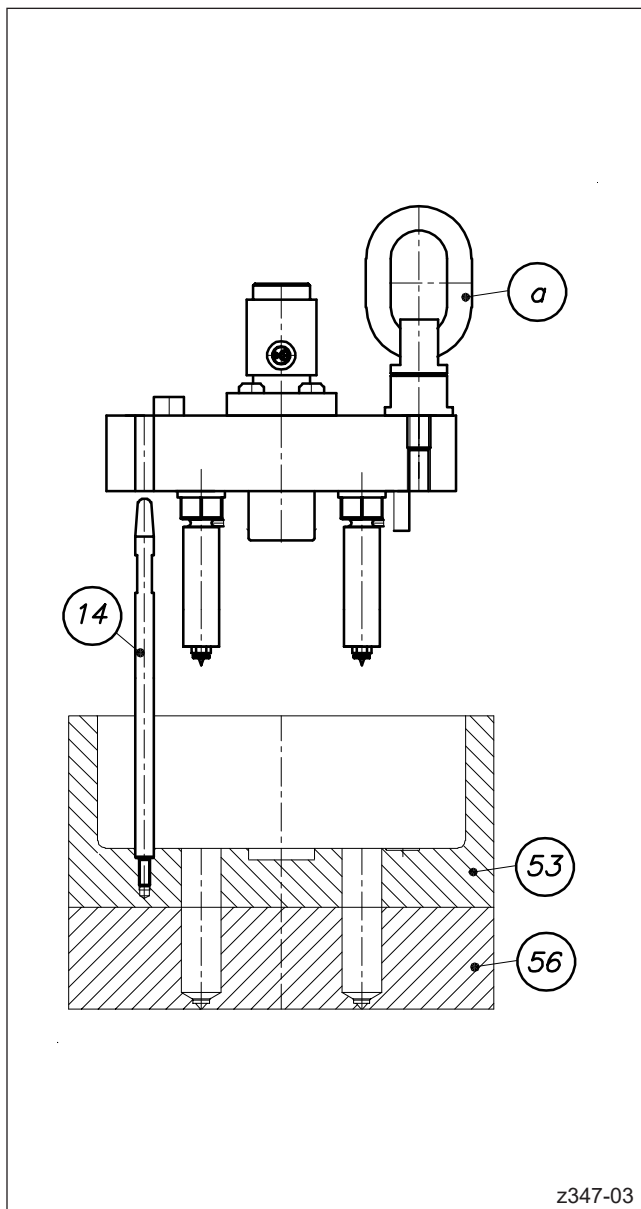

Picture 25: Preliminary measures



WARNING!



Suspended load

Death and severe crushing of body or extremities.

- Keep clear of and do not pass under suspended loads.
- Keep clear of suspended loads while they are being transported.
- Do not touch lifting devices and lifting accessories while lifting the load.
- Only lift, transport and set down loads, if you have received appropriate training.
- Only use suitable and undamaged lifting devices and lifting accessories which are checked regularly.
- Do not exceed the maximum load limit of lifting accessories.

Sharp edges and heavy components

- Cut injuries to body and extremities, mainly to the hands.
- Crushing of fingers or hand.

Hot surfaces

Burns to the body caused by hot surfaces.



CAUTION!

Respect operating temperatures

Each hot runner system is individually designed for the material to be processed. Therefore, the specified operating temperatures must be observed. The temperature difference ΔT between hot runner temperature T_{HK} (processing temperature) and mould temperature T_{WZ} , must be strictly adhered to.

- Non-observance may cause an escape of melt inside the mould (ΔT too low) or damage to components (ΔT too large).

1. Lift the pre-installed system carefully out of the transport crate. EWIKON recommends to use attachment swivels M12 only (pos. a, min. quality category 8 = 500 kg loading capacity for $\alpha = 0^\circ$, see chapter „5.3.1 Tools and operating materials“). Distance bolts with appropriate length (item number see EWIKON L2X catalogue) may be used in exceptional cases only. Please pay attention to the notes in chapter „5.1 Transport“.
2. Screw the enclosed centring aids (pos. 14) into the nozzle retainer frame plate (pos. 53).
3. Connect the hot runner controller to the connector box. Please pay attention to the notes in chapter „5.6 Electrical connection of hot runner systems“.
4. Heat the manifold up to 120 °C.

Installation

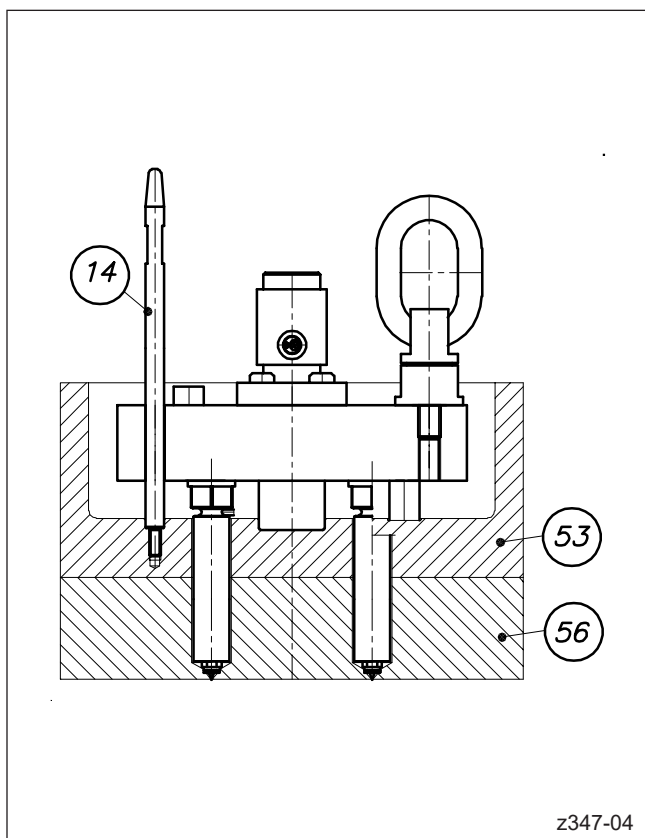

Picture 26: Installation - inserting the system

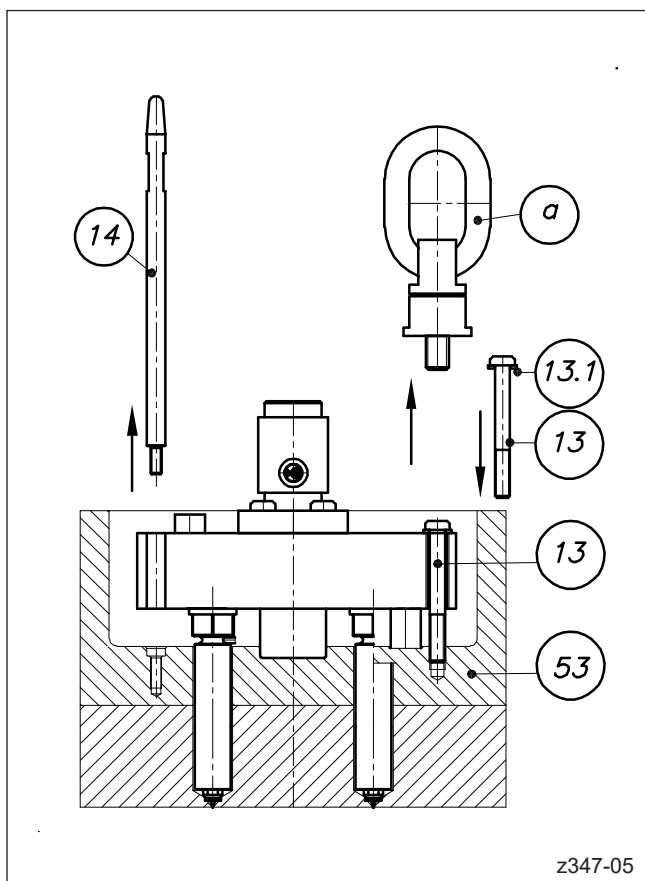

Picture 27: Installation - screw connecting the system



WARNING!



Suspended load

Death and severe crushing of body or extremities.

- Keep clear of and do not pass under suspended loads.
- Keep clear of suspended loads while they are being transported.
- Do not touch lifting devices and lifting accessories while lifting the load.
- Only lift, transport and set down loads, if you have received appropriate training.
- Only use suitable and undamaged lifting devices and lifting accessories which are checked regularly.
- Do not exceed the maximum load limit of lifting accessories.

Sharp edges and heavy components

- Cut injuries to body and extremities, mainly to the hands.
- Crushing of fingers or hand.

Hot surfaces

Burns to the body caused by hot surfaces.

1. Apply a thin coat of high performance grease (see chapter „5.3.1 Tools and operating materials“) to the centring aids (pos. 14). Slide the system carefully over the centring aids and insert it into the nozzle retainer frame plate (pos. 53). Avoid tilting in order not to damage the sealing collars of the tip inserts or the screw-on gate bushes.
2. Unscrew and remove the centring aids (pos. 14).
3. Unscrew and remove the attachment swivels A (pos. a). Screw the manifold to the nozzle retainer frame plate (pos. 53) by using socket head screws M8 with flat head (pos. 13, DIN 6912 - min. 8.8) and plain washers (pos. 13.1, ISO 7092). Screw the socket head screws in to the stop, then tighten with matching torque. See chapter „9.2 Tightening torques for manifold screw connections and retaining screws“. Before installation apply high temperature installation paste (see chapter „5.3.1 Tools and operating materials“) to the socket head screws (pos. 13).

Check of clearance ΔS , installation of clamping plate and locating ring

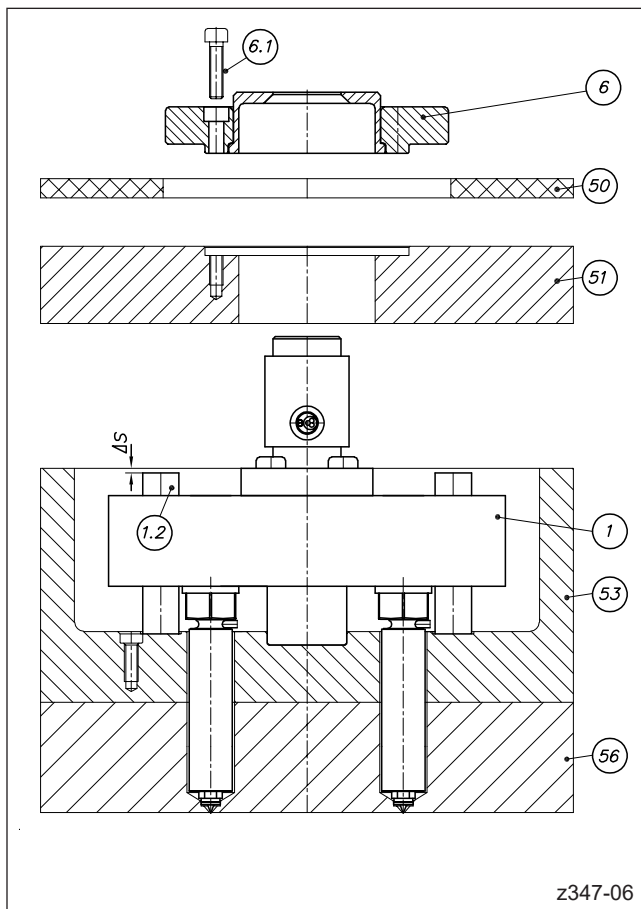

Picture 28: Check of clearance ΔS and subsequent installation steps



WARNING!



Sharp edges and heavy components

- Cut injuries to body and extremities, mainly to the hands.
- Crushing of fingers or hand.

Hot surfaces

Burns to the body caused by hot surfaces.



NOTE!

All clearances must be checked in cold condition!

In case of deviations the clearances must be adjusted in an appropriate way (e.g. by machining the nozzle retainer frame plate or the pressure pads of the manifold).

Attention: The adjustment must not have influence on the dimension X of the nozzle!

1. Let the manifold cool down to room temperature.
2. Check the clearance ΔS between the surface of the upper pressure pad (pos. 1.2) and the surface of the nozzle retainer frame plate (pos. 53) and compare it to the value given in the drawing provided by EWIKON.
3. Install the clamping plate (pos. 51) and the insulating plate (pos. 50).
4. Install the locating ring (pos. 6) and fix it with socket head screws (pos. 6.1, ISO 4762 - 12.9). Tighten with matching torque. See chapter „9. Tightening torques“.
5. **For valve gate systems:** connect the supply lines to the connector block.
6. In order to clearly identify the hot runner system attach the type plate included in the delivery prominently to the operator side of the mould.

5.6 Electrical connection of hot runner systems

5.6.1 Safety instructions



HAZARD!

Connected power supply during installation

Risk of deadly electric shock or severe injuries due to live components.

- The HPS III hot runner system, the single tip, the hot half and the mould have to be disconnected from the voltage source during installation.

Insufficient protective conductor connection to the injection moulding machine

Risk of deadly electric shock or severe injuries due to live components.

The operator must ensure that during startup of hot runner single tips or hot runner systems all electrical system components have been wired to the protective conductor system of the injection moulding machine or are protected by equivalent safety measures before applying electric voltage. When applying electric voltage to systems or to system components beyond specified normal operation, sufficient ground earth connection or equivalent safety measures must be ensured for each component.



WARNING!

Control of live components before installation

The electrical equipment of the hot runner system should be checked, especially those areas which will no longer be accessible after installation. Physical injuries such as an electric shock can be prevented that way

Please check

- if cables are kinked or squeezed.
 - if cable insulations are undamaged.
-

**NOTE!****Mechanical stress of cable ends**

The cable ends must not be subject to tensile stress.

Protect the cable ends

When wiring the system make sure that the thermo and power lines do not protrude from the outer edges of the mould and are protected against damage. The distances between hot runner and cables inside the mould have to be dimensioned in such a way that there is no damage to the components caused by excessive heat.

Secure the connection cables

All connecting cables have to be secured in such a way that they do not get pinched when they are installed in the mould (use cable binders and/or covering plates for the recesses).

Adhere to bending radiuses

The bending radiuses of the coil heater and the thermocouple have to be adhered to. The minimum bending radius is 15 mm. The connection can only be bended once.

General instructions for wiring

- Place the cables in such a way that there is no direct contact with hot surfaces and that the expected temperature is below the maximum allowable temperature for the wire insulation.
- Place the cables in such a way that they can not get pinched when the hot runner system is installed.
- When placing the cables keep clear of sharp edges.

5.6.2 General information

Wiring of the hot runner components must be performed by qualified staff according to DIN EN 60204-1 and the generally recognized codes of practice.

Heaters designed for a rated voltage of 230V AC are used. Please make sure that the voltage applied corresponds to this specification. The heaters are connected to the plug according to the arrangement given in the wiring diagram of the respective hot runner system. The following pictures give an overview of the cable assignment of HPS III nozzles and manifolds.

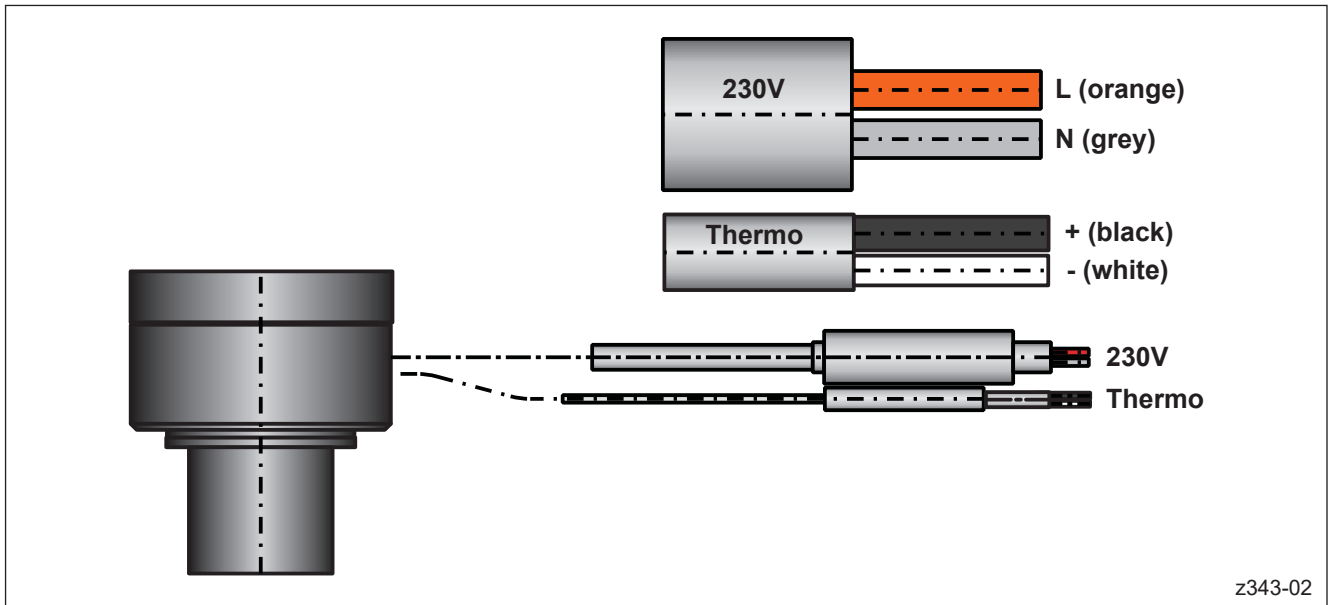

Picture 29: Cable assignment of HPS III-S / pro SHOT nozzles (one control zone)

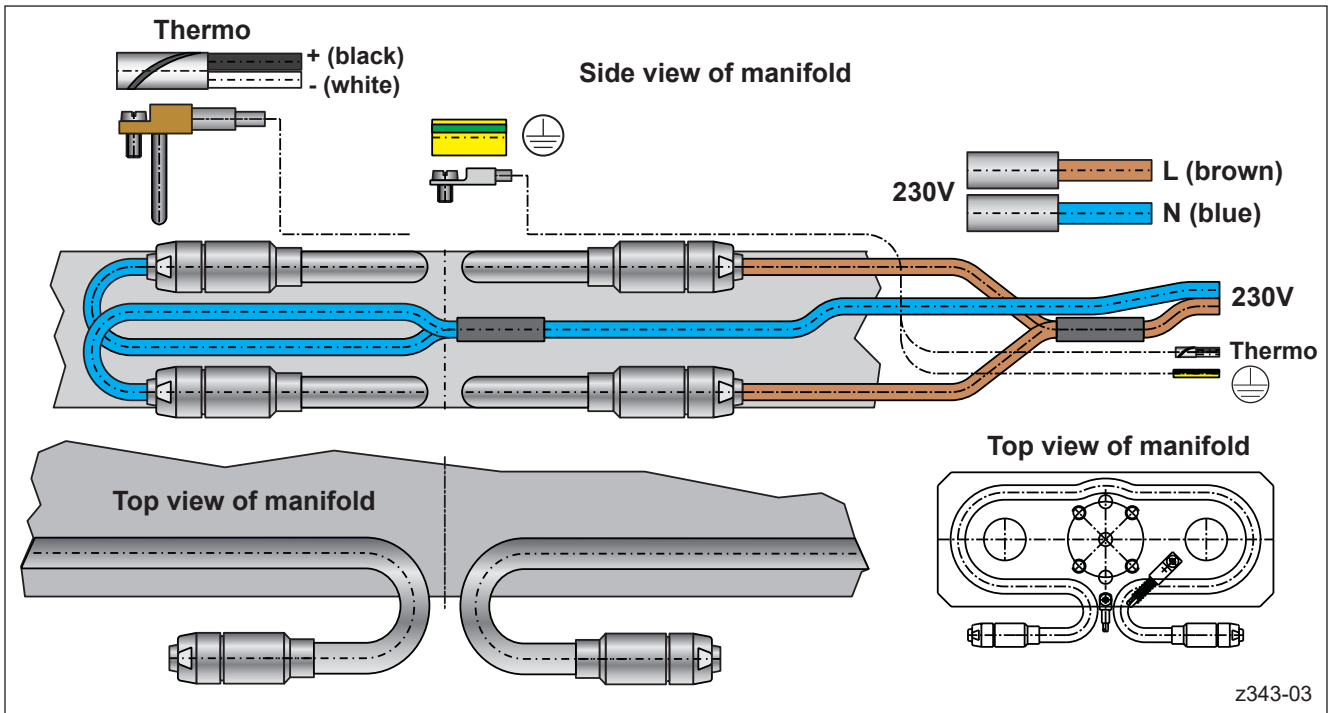

z343-03

Picture 30: Cable assignment of HPS III manifolds (shown: one control zone)

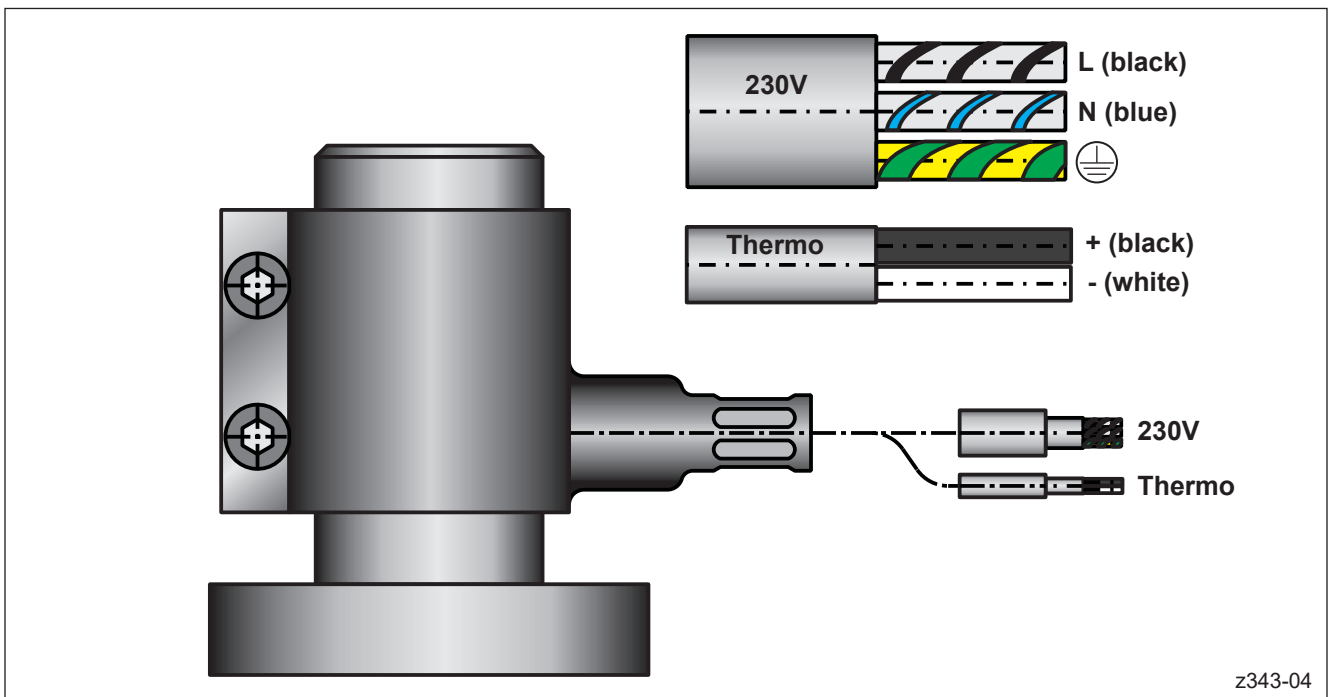

z343-04

Picture 31: Cable assignment of heater bands for sprue bushes (one control zone)

Generally the cable pairs for heaters are brown and blue (manifold heaters) and orange and grey (nozzle heaters) respectively. A sufficient protective earthing of the hot runner system must be ensured.

Furthermore, thermocouples type J (Fe-CuNi) are used. The hot runner controller used must be designed to work with that type. The wiring follows the wiring plan of the hot runner system. Generally the cable pairs are black (+) and white (-).

General information for wiring of standard hot runner systems

Position of nozzles in the mould

Most EWIKON hot runner systems are delivered as complete hot halves. As far as there is no differing specification from the customer side, the position of the nozzles is defined as following: When viewing from the parting line in direction of the nozzle tips, the nozzles are numbered line-by-line from top left to bottom right according to the scheme shown below. If the manifold has multiple heaters, the same numbering scheme is applied. The power and thermo collective plugs are numbered consecutively:

(230 V: X-1.1, X-2.1, X-3.1... / Thermo: X-1.2, X-2.2, X-3.2....).

EWIKON recommends to apply this numbering scheme also when purchasing components instead of hot halves.

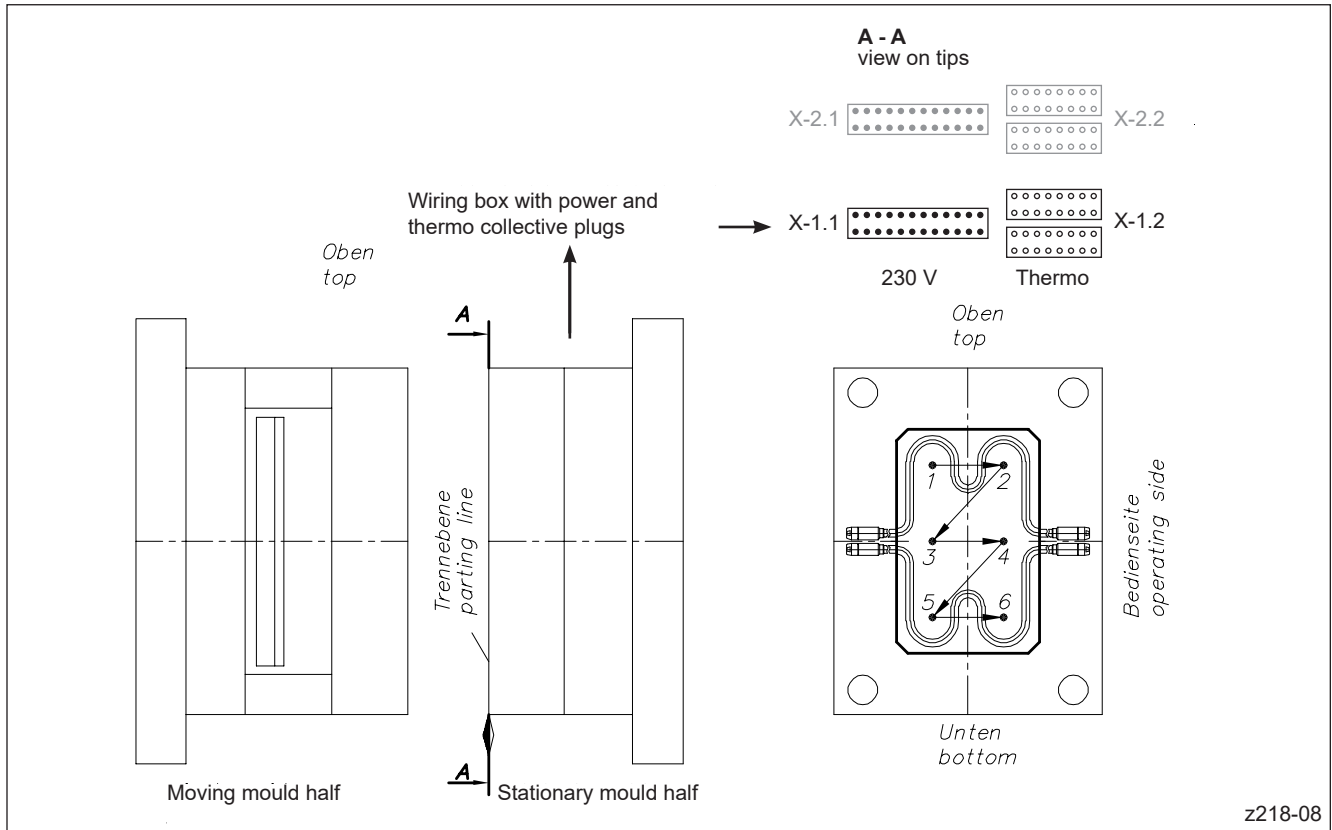

Picture 32: General information for wiring of standard hot runner systems

z218-08

Wiring order (Example: 6-drop system):

The control zones are numbered consecutively, beginning at the position of the first nozzle (top left). Each control zone has a heater and a thermocouple assigned. First all nozzles (H-01 - H-06) should be wired, then all manifold heaters (M-01 - M-02) and at last the heater of the connecting nozzle (CN-01). The contact allocation follows DIN 16765, part A.

Detailed wiring instructions for standard system configurations are shown on the following pages.

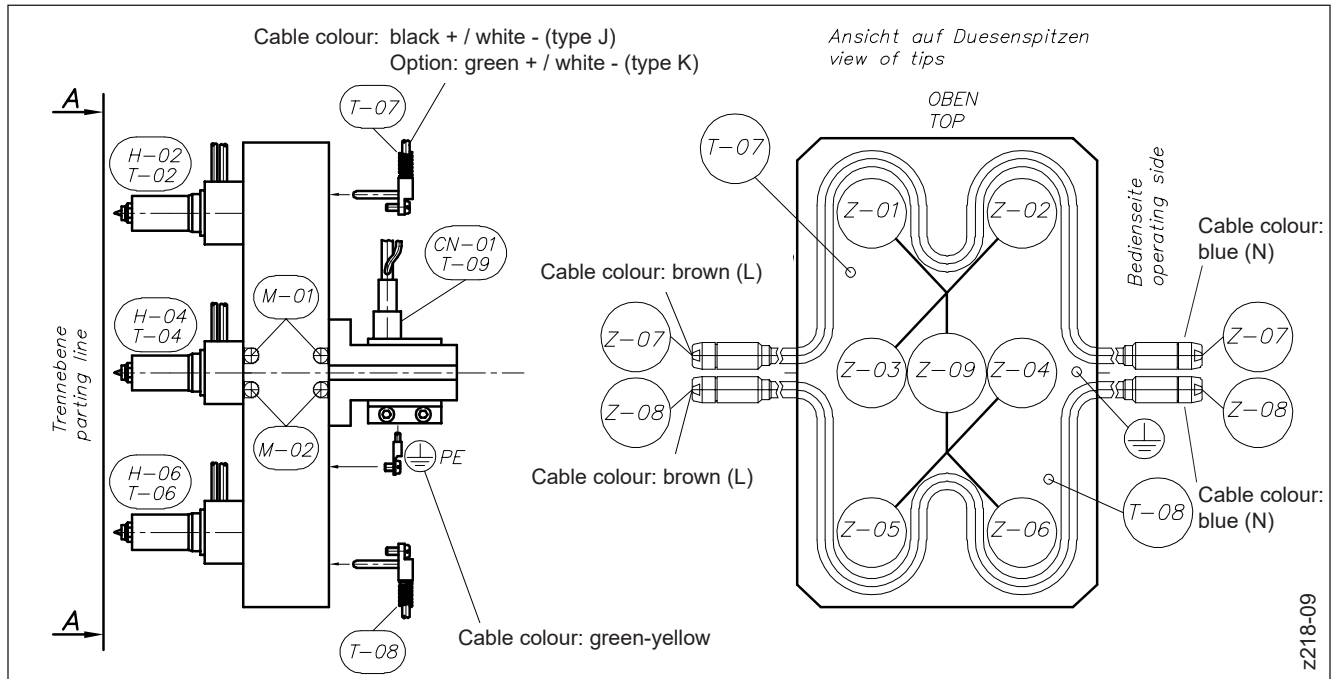

Picture 33: Wiring order (example: 6-drop system)

Key to the symbols	
Z	Control zone
H	Heater nozzle
M	Heater manifold
CN	Heater band sprue bush
T	Thermocouple
PE	Protective earth conductor
L	Phase conductor
N	Neutral conductor

Control zone Z	230 V	Thermo
Z-01	H-01	T-01
Z-02	H-02	T-02
Z-03	H-03	T-03
Z-04	H-04	T-04
Z-05	H-05	T-05
Z-06	H-06	T-06
Z-07	M-01	T-07
Z-08	M-02	T-08
Z-09	CN-01	T-09

5.6.3 Wiring of 1-drop hot runner systems

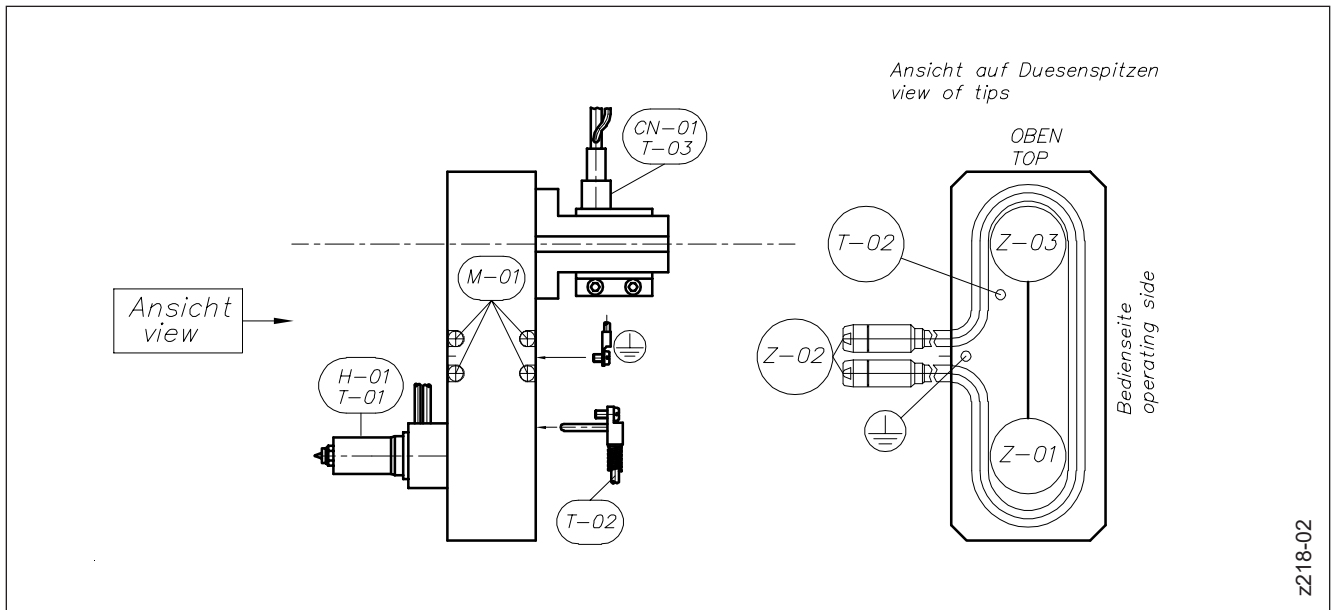

Picture 34: Wiring of standard-1-drop hot runner systems

Key to the symbols	
Z	Control zone
H	Heater nozzle
M	Heater manifold
CN	Heater band sprue bush
T	Thermocouple
PE	Protective earth conductor
L	Phase conductor
N	Neutral conductor
●	male
○	female

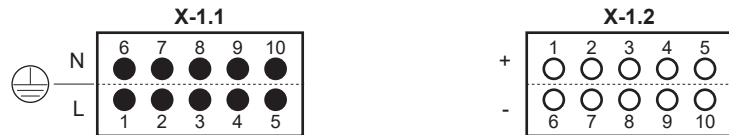

Control zone Z	230 V		Thermo		
	Plug 230 V / 10-pin No. = X...	Contact L / N	Plug thermo / 10-pin No. = X...	Contact + / -	
Z-01	X-1.1	H-01	X-1.2	T-01	1 / 6
Z-02	X-1.1	M-01	X-1.2	T-02	2 / 7
Z-03	X-1.1	CN-01	X-1.2	T-03	3 / 8

or

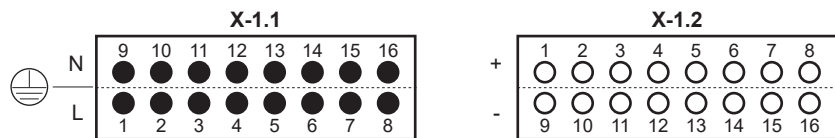

Control zone Z	230 V		Thermo		
	Plug 230 V / 16-pin No. = X...	Contact L / N	Plug thermo / 16-pin No. = X...	Contact + / -	
Z-01	X-1.1	H-01	X-1.2	T-01	1 / 9
Z-02	X-1.1	M-01	X-1.2	T-02	2 / 10
Z-03	X-1.1	CN-01	X-1.2	T-03	3 / 11

5.6.4 Wiring of 2-drop hot runner systems

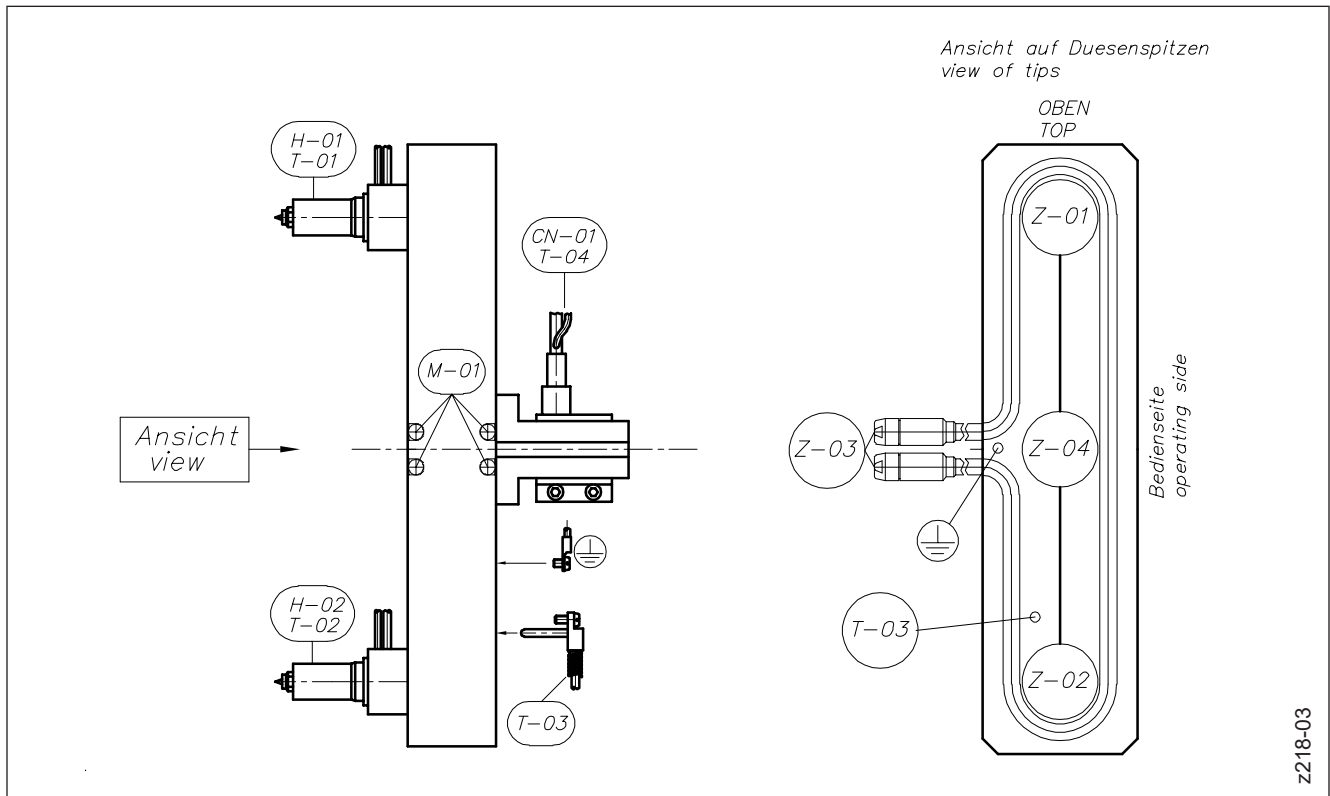

Z218-03

Picture 35: Wiring of standard-2-drop hot runner systems

Key to the symbols	
Z	Control zone
H	Heater nozzle
M	Heater manifold
CN	Heater band sprue bush
T	Thermocouple
PE	Protective earth conductor
L	Phase conductor
N	Neutral conductor
●	male
○	female



Control zone Z	230 V		Thermo			
	Plug 230 V / 10-pin No. = X...	Contact L / N	Plug thermo / 10-pin No. = X...	Contact + / -		
Z-01	X-1.1	H-01	X-1.2	T-01	1 / 6	
Z-02	X-1.1	H-02	X-1.2	T-02	2 / 7	
Z-03	X-1.1	M-01	X-1.2	T-03	3 / 8	
Z-04	X-1.1	CN-01	X-1.2	T-04	4 / 9	

or

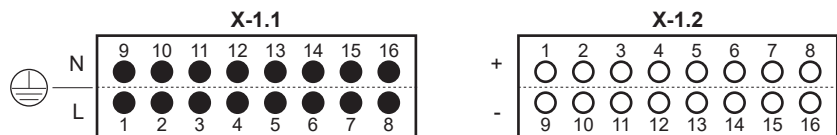

Control zone Z	230 V		Thermo			
	Plug 230 V / 16-pin No. = X...	Contact L / N	Plug thermo / 16-pin No. = X...	Contact + / -		
Z-01	X-1.1	H-01	X-1.2	T-01	1 / 9	
Z-02	X-1.1	H-02	X-1.2	T-02	2 / 10	
Z-03	X-1.1	M-01	X-1.2	T-03	3 / 11	
Z-04	X-1.1	CN-01	X-1.2	T-04	4 / 12	

5.6.5 Wiring of 4-drop hot runner systems (manifold with 2 control zones)

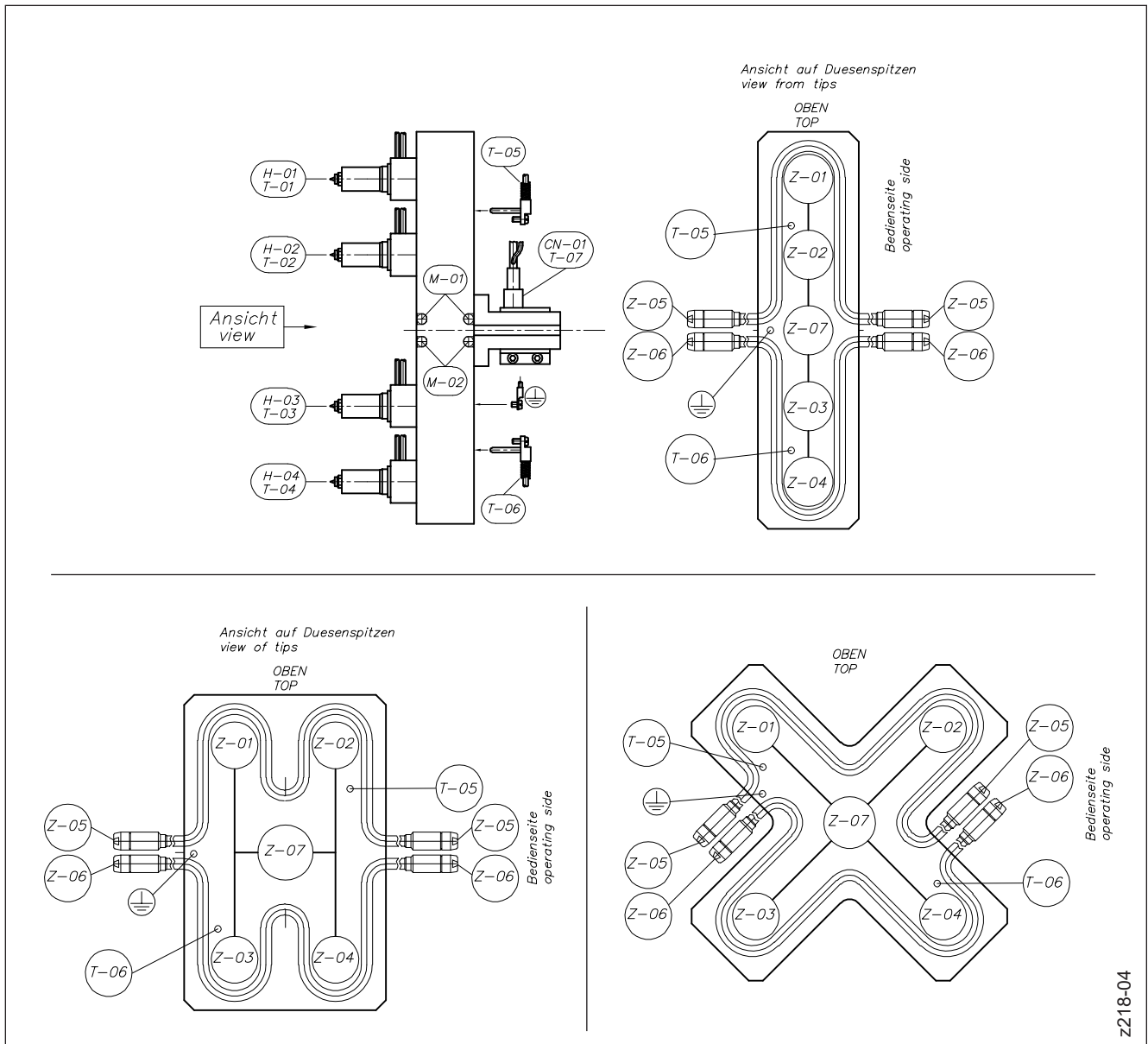

Picture 36: Wiring of standard-4-drop hot runner systems (manifold with two control zones)

Key to the symbols	
Z	Control zone
H	Heater nozzle
M	Heater manifold
CN	Heater band sprue bush
T	Thermocouple
PE	Protective earth conductor
L	Phase conductor
N	Neutral conductor
●	male
○	female

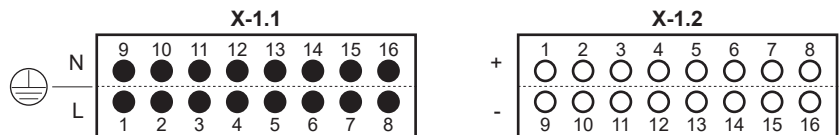

Control zone Z	230 V			Thermo		
	Plug 230 V / 16-pin No. = X...	Contact L / N		Plug thermo / 16-pin No. = X...	Contact + / -	
Z-01	X-1.1	H-01	1 / 9	X-1.2	T-01	1 / 9
Z-02	X-1.1	H-02	2 / 10	X-1.2	T-02	2 / 10
Z-03	X-1.1	H-03	3 / 11	X-1.2	T-03	3 / 11
Z-04	X-1.1	H-04	4 / 12	X-1.2	T-04	4 / 12
Z-05	X-1.1	M-01	5 / 13	X-1.2	T-05	5 / 13
Z-06	X-1.1	M-02	6 / 14	X-1.2	T-06	6 / 14
Z-07	X-1.1	CN-01	7 / 15	X-1.2	T-07	7 / 15

5.6.6 Wiring of 6-drop hot runner systems (manifold with 2 control zones)

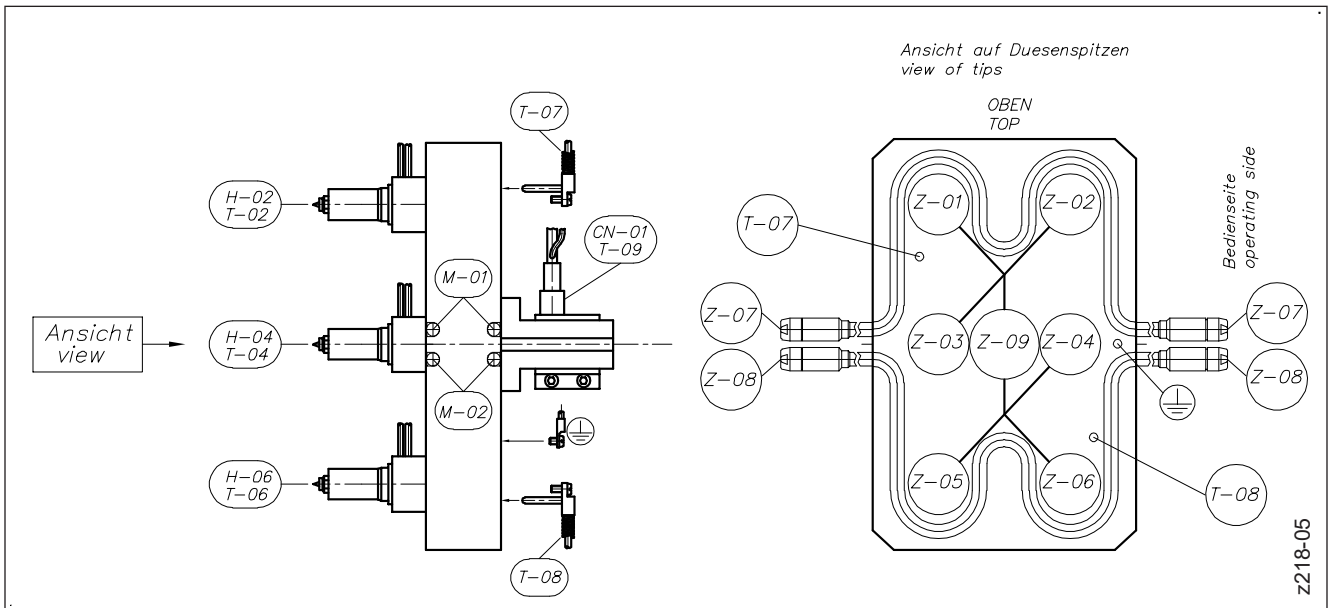

Picture 37: Wiring of standard-6-drop hot runner systems (manifold with two control zones)

Key to the symbols	
Z	Control zone
H	Heater nozzle
M	Heater manifold
CN	Heater band sprue bush
T	Thermocouple
PE	Protective earth conductor
L	Phase conductor
N	Neutral conductor
●	male
○	female

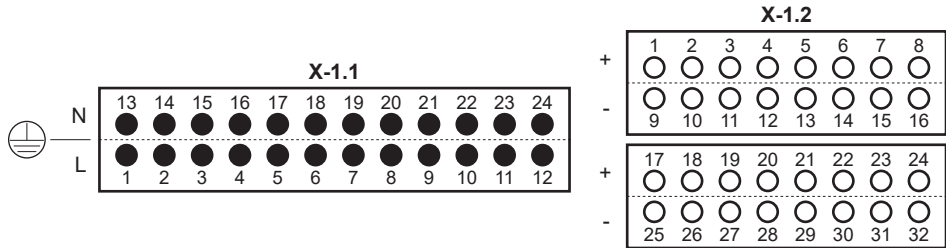

Control zone Z	230 V		Thermo			
	Plug 230 V / 24-pin No. = X...	Contact L / N	Plug thermo / 32-pin No. = X...	Contact + / -		
Z-01	X-1.1	H-01	1 / 13	X-1.2	T-01	1 / 9
Z-02	X-1.1	H-02	2 / 14	X-1.2	T-02	2 / 10
Z-03	X-1.1	H-03	3 / 15	X-1.2	T-03	3 / 11
Z-04	X-1.1	H-04	4 / 16	X-1.2	T-04	4 / 12
Z-05	X-1.1	H-05	5 / 17	X-1.2	T-05	5 / 13
Z-06	X-1.1	H-06	6 / 18	X-1.2	T-06	6 / 14
Z-07	X-1.1	M-01	7 / 19	X-1.2	T-07	7 / 15
Z-08	X-1.1	M-02	8 / 20	X-1.2	T-08	8 / 16
Z-09	X-1.1	CN-01	9 / 21	X-1.2	T-09	17 / 25

5.6.7 Wiring of 8-drop hot runner systems (manifold with 2 control zones)

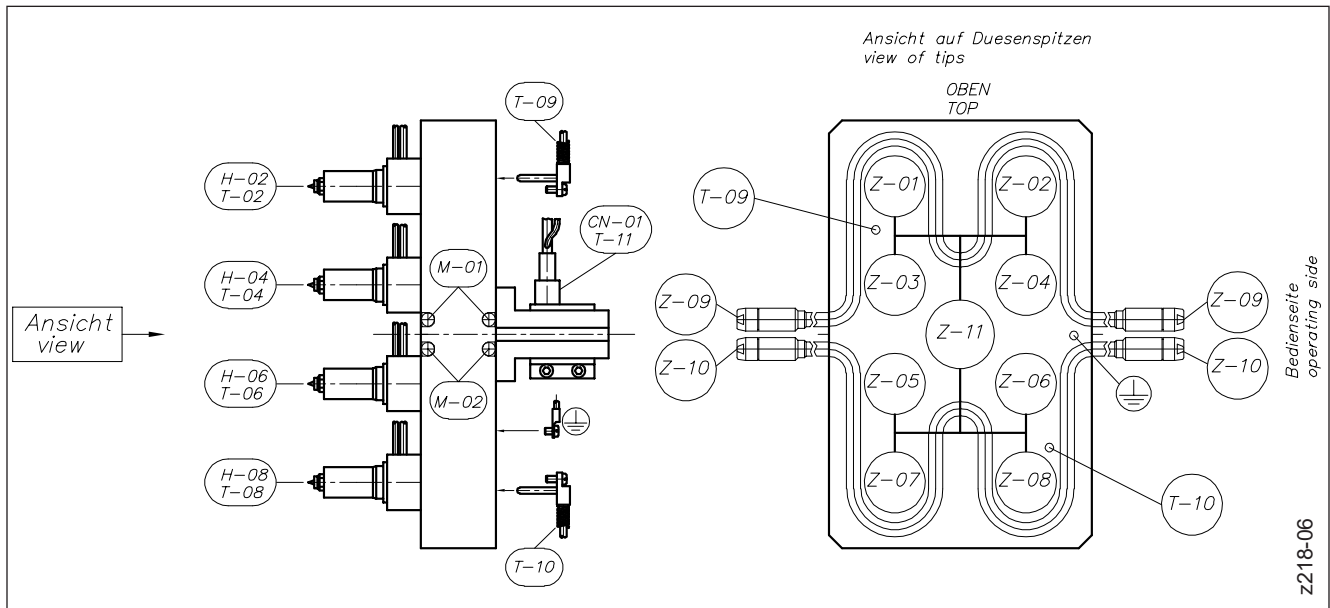

Picture 38: Wiring of standard-8-drop hot runner systems (manifold with two control zones)

Key to the symbols	
Z	Control zone
H	Heater nozzle
M	Heater manifold
CN	Heater band sprue bush
T	Thermocouple
PE	Protective earth conductor
L	Phase conductor
N	Neutral conductor
●	male
○	female

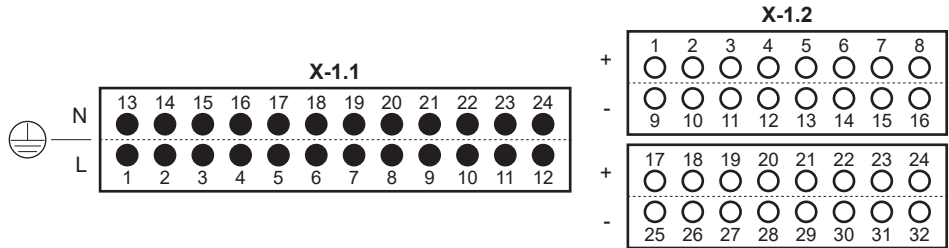

Control zone Z	230 V		Thermo		
	Plug 230 V / 24-pin No. = X...	Contact L / N	Plug thermo / 32-pin No. = X...	Contact + / -	
Z-01	X-1.1	H-01	X-1.2	T-01	1 / 9
Z-02	X-1.1	H-02	X-1.2	T-02	2 / 10
Z-03	X-1.1	H-03	X-1.2	T-03	3 / 11
Z-04	X-1.1	H-04	X-1.2	T-04	4 / 12
Z-05	X-1.1	H-05	X-1.2	T-05	5 / 13
Z-06	X-1.1	H-06	X-1.2	T-06	6 / 14
Z-07	X-1.1	H-07	X-1.2	T-07	7 / 15
Z-08	X-1.1	H-08	X-1.2	T-08	8 / 16
Z-09	X-1.1	M-01	X-1.2	T-09	17 / 25
Z-10	X-1.1	M-02	X-1.2	T-10	18 / 26
Z-11	X-1.1	CN-01	X-1.2	T-11	19 / 27

5.6.8 Wiring of 8-drop hot runner systems (manifold with 4 control zones)

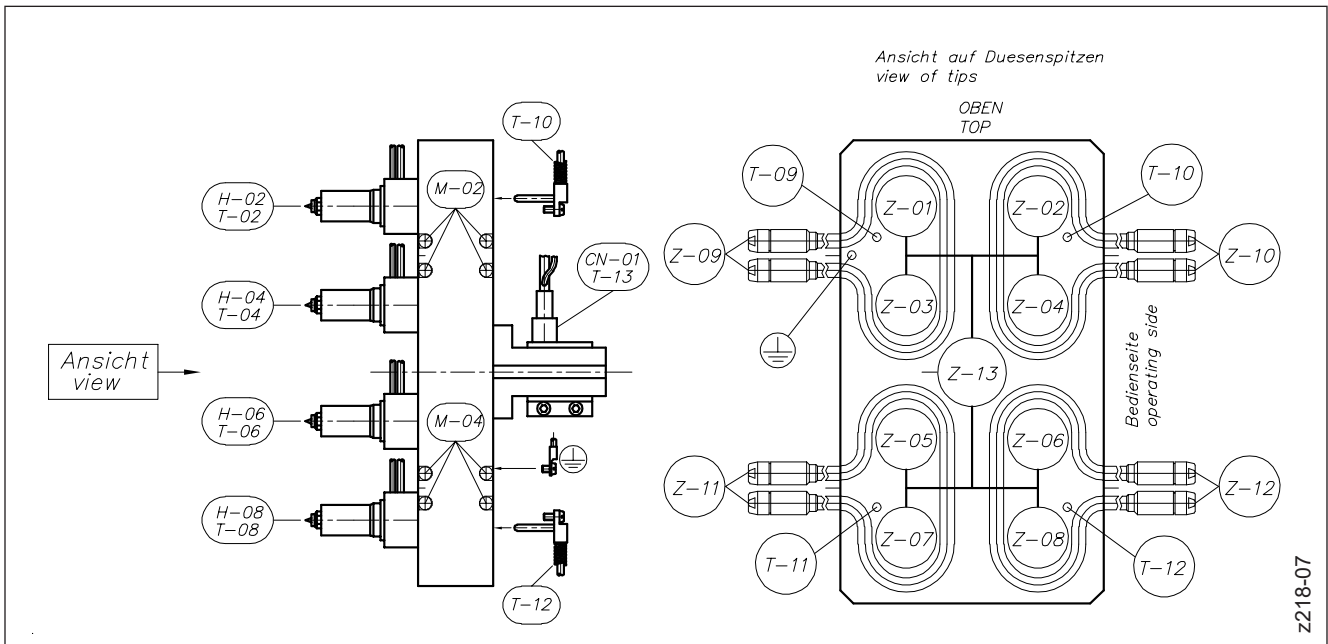

Picture 39: Wiring of standard-8-drop hot runner systems (manifold with four control zones)

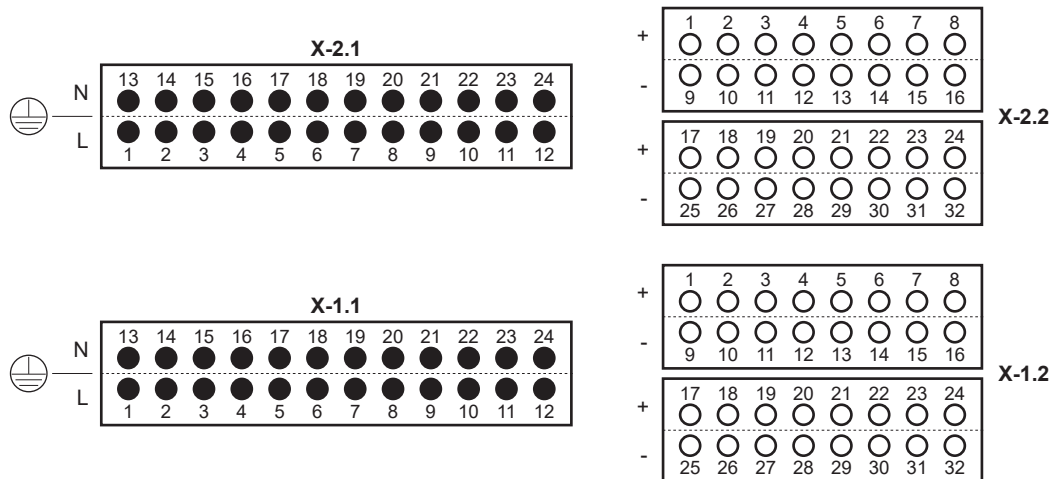

Key to the symbols	
Z	Control zone
H	Heater nozzle
M	Heater manifold
CN	Heater band sprue bush
T	Thermocouple
PE	Protective earth conductor
L	Phase conductor
N	Neutral conductor
●	male
○	female

Control zone Z	230 V		Thermo			
	Plug 230 V / 24-pin No. = X...	Contact L / N	Plug thermo / 32-pin No. = X...	Contact + / -		
Z-01	X-1.1	H-01	1 / 13	X-1.2	T-01	1 / 9
Z-02	X-1.1	H-02	2 / 14	X-1.2	T-02	2 / 10
Z-03	X-1.1	H-03	3 / 15	X-1.2	T-03	3 / 11
Z-04	X-1.1	H-04	4 / 16	X-1.2	T-04	4 / 12
Z-05	X-1.1	H-05	5 / 17	X-1.2	T-05	5 / 13
Z-06	X-1.1	H-06	6 / 18	X-1.2	T-06	6 / 14
Z-07	X-1.1	H-07	7 / 19	X-1.2	T-07	7 / 15
Z-08	X-1.1	H-08	8 / 20	X-1.2	T-08	8 / 16
Z-09	X-1.1	M-01	9 / 21	X-1.2	T-09	17 / 25
Z-10	X-1.1	M-02	10 / 22	X-1.2	T-10	18 / 26
Z-11	X-1.1	M-03	11 / 23	X-1.2	T-11	19 / 27
Z-12	X-1.1	M-04	12 / 24	X-1.2	T-12	20 / 28
Z-13	X-2.1	CN-01	1 / 13	X-2.2	T-13	1 / 9

5.7 Checks after installation

To be checked in cold condition

- Bores and connections for media (e.g. cooling circuits, hydraulic circuits) (optical check)
- Allocation of wiring according to the wiring scheme (see order specific documents)
- Resistance of the protective earth conductor
- Insulation resistances of the heating zones
- Check of cooling (function, correct piping): Are all components that require cooling supplied with water (is the flow rate sufficient)?



CAUTION!

PPE

Respect operating temperatures

For all further checks the HPS III hot runner system must be heated to operating temperature in order to avoid damage to hot runner components.

Each hot runner system is individually designed for the material to be processed. Therefore, the specified operating temperatures must be observed. The temperature difference ΔT between hot runner temperature T_{HK} (processing temperature) and mould temperature T_{WZ} , must be strictly adhered to.

- Non-observance may cause an escape of melt inside the mould (ΔT too low) or damage to components (ΔT too large).



Check of heaters by heating the HPS III hot runner system to operating temperature

- Switch on the mould cooling.
- Check if the thermocouple and power connections are allocated correctly by heating up each zone separately (for a short time)
- Check response of the respective thermocouple
- When using a EWIKON controller this procedure can be automatically carried out by using the diagnosis function.

To be checked in heated condition (operating temperature)

- Leak tightness and function of drive units (hydraulic fluid, pressurised air) by repeatedly moving the valve pin to the end positions in manual mode while the mould is opened.
- Valve pin position (move valve pin to end position „closed“).
- Valve pin function (move valve pin repeatedly into end positions „open“ and „closed“).
- Leak tightness and function of mould cooling.

6. Start-up and instructions for operation

6.1 Safety instructions



WARNING!

Unwanted sudden escape of melt caused by thermal degradation or gas release of plastic material

Unwanted escape of melt caused by different thermal expansion of materials due to temperature differences

Heavy burns to body and extremities.

- Before operation the system must be heated through for at least 3-5 min.
- Only process materials which are approved for use with the system.
- The safety devices of the injection moulding machine must be active and working

PPE



HAZARD!

Insufficient protective conductor connection to the injection moulding machine

Risk of deadly electric shock or severe injuries due to live components.



The operator must ensure that during startup of hot runner single tips or hot runner systems all electrical system components have been wired to the protective conductor system of the injection moulding machine or are protected by equivalent safety measures before applying electric voltage. When applying electric voltage to systems or to system components beyond specified normal operation, sufficient ground earth connection or equivalent safety measures must be ensured for each component.

Raised injection pressure

The system is designed for an injection pressure of 2000 bar. When the cavity pressure is too high (e.g. by overpacking a cavity without limiting the injection pressure) components of the hot runner system may break and hot plastic melt can escape.

Injection moulding processes must only be carried out with maximum pressures of 2000 bar. If the process requires higher pressures a written permission of EWIKON Heißkanalsysteme GmbH is needed.

PPE



**CAUTION!****PPE**

A HPS III hot runner system must only be started up when used as intended within an injection mould.

**Respect operating temperatures**

For all further checks the HPS III hot runner system must be heated to operating temperature in order to avoid damage to hot runner components.



Each hot runner system is individually designed for the material to be processed. Therefore, the specified operating temperatures must be observed. The temperature difference ΔT between hot runner temperature T_{HK} (processing temperature) and mould temperature T_{WZ} , must be strictly adhered to.

- Non-observance may cause an escape of melt inside the mould (ΔT too low) or damage to components (ΔT too large).

Improper processing of thermoplastics in the injection moulding process

The guidelines of the material manufacturer such as processing temperature and mould temperature must be observed. Otherwise the moulded parts can be faulty or the hot runner system can be damaged.

Risk of injuries during installation

During installation the following injuries may occur:

- Cut injuries due to sharp edges.
- Crushing of fingers or hand.

Leakage during operation

Using a wrong combination of radii of sprue bush and machine nozzle can result in unwanted escape of melt during the injection moulding process.

Observe system temperatures during installation / disassembly

Damage to the melt seal.

- Disassemble contour plate in cold condition.

**NOTE!**

When processing materials with flame retardant additives or glass fibre reinforcements we recommend to purge the hot runner system with natural material of the same type without additives after end of production. This will facilitate the next start-up.

When conducting colour and material changes it is advantageous if the contour plate can be separated from the stationary mould half (nozzle side). Thus, the nozzle tips become accessible for cleaning and maintenance purposes. This is required when a colour change can not be successfully carried out by just purging the system.

6.2 Requirements for operation

- The radius of the sprue bush (R) or the radius of the contact surface of a single tip respectively has to be adapted to the radius of the machine nozzle (R_M) (recommendation: $R > R_M + 1$).
- For a better decompression the bore in the machine nozzle has to be adapted to the bore in the sprue bush or the single tip respectively (machine nozzle bore max. 1 mm smaller).
- The injection unit stays attached to the mould during cycle.
- Connect power cable, thermocouple collective cable and ground cable.
- Check if the thermocouple and power connections are allocated correctly by heating up each zone separately (for a short time).
- Before start-up valve gate systems have to be checked on tightness of water, oil and compressed air connections.
- In order to clearly identify the hot runner system attach the type plate with the order number prominently to the operator side of the mould.



NOTE!

When operating single tips the maximum contact pressure of the injection unit must be obeyed!

Type of single tip	Flow channel diameter [mm]	Max. contact pressure [KN]
HPS III-SXE / HPS III-NVI	6	30
	9	50
	12	90
	18	90
HPS III-MHR 100/200 / HPS III-MHL 100/200		30
HPS III-MHR 111/112		50

6.3 Start-up of a HPS III hot runner system



NOTE!

In general the start-up of a hot runner system with **HPS III single tips**, a **L2X system** as well as a **valve gate system** is carried out analogously to the start-up of a system with HPS III-S / pro SHOT nozzles. Possible differences are specified in the text. Please pay special attention to the instructions for operating a valve gate system in chapter „6.4 Instructions for the operation of valve gate systems“.

An HPS III hot runner system is not designed and suitable for dry running/validation running at operating temperatures without plastic.

6.3.1 First-time start-up and filling of a HPS III hot runner system

- Switch on the mould cooling.
- Mould and barrel should have reached the recommended temperatures.
- Switch on the hot runner and let the humidity from the heaters dry out at a temperature between 100 °C and 120 °C for approx. 10 minutes (sequential start /compound heating mode of the controller).
- Set processing temperature and heat system for 3 - 5 minutes (sequential start /compound heating mode) so that the preload is ensured.
- Make sure that there is a sufficient barrel pressure. Without that leakage might occur between machine nozzle and mould. Fill the hot runner with approx. 300 - 400 bar back pressure until plastic emerges at the gates.
- When filling the hot runner system use natural material without additives especially if colour changes are planned or if materials with flame retardant additives and glass fibres respectively are used.
- Start moulding process.
- If intense mould cooling is required increase temperature by approx. 20 °C - 25 °C if necessary.

6.3.2 Start-up of an already filled HPS III hot runner system

- Switch on the mould cooling.
- Mould and barrel should have reached the recommended temperatures.
- Switch on the hot runner and let the humidity from the heaters dry out at a temperature between 100 °C and 120 °C for approx. 10 minutes (sequential start /compound heating mode of the controller).
- Set processing temperature and heat system for 3 - 5 minutes (sequential start /compound heating mode) so that the preload is ensured.
- When material melts at the sprue bush remove cold slug and purge machine barrel – then start up mould.
- Start moulding process.
- If intense mould cooling is required increase temperature by approx. 20 °C - 25 °C if necessary.

6.3.3 Colour and material changes

1. In order to successfully carry out a colour change the hot runner system needs to be filled with natural material.
2. Fill the hot runner system as described under „6.3.1 First-time start-up and filling of a HPS III hot runner system“ .
3. Mould articles using the first colour.
4. For the colour change increase barrel temperature by 20 - 40 °C and change to natural material.
5. Purge the barrel with natural material first, then purge the hot runner system and the barrel together with natural material.
6. When approx. 95% of the purged material contains of natural material, increase the temperature of the hot runner by 30 - 50 °C and continue to purge with natural material until no further improvement can be achieved.
7. Set temperature back to standard settings.
8. Start moulding with new colour.

**NOTE!**

If despite of intensive purging old material still remains visible in the moulded part (visible flow marks on the surface or inside transparent parts) the so called „cap“ the area of frozen plastic between nozzle tip and gate must be removed.

Recommended tools for the following installation steps

The use of non-approved assembly tools may result in damage to the HPS III nozzles.

- Wire brush, soft (preferably brass wire, do not use brass-coated wire).
- Side cutter (preferably side cutter for electronics)

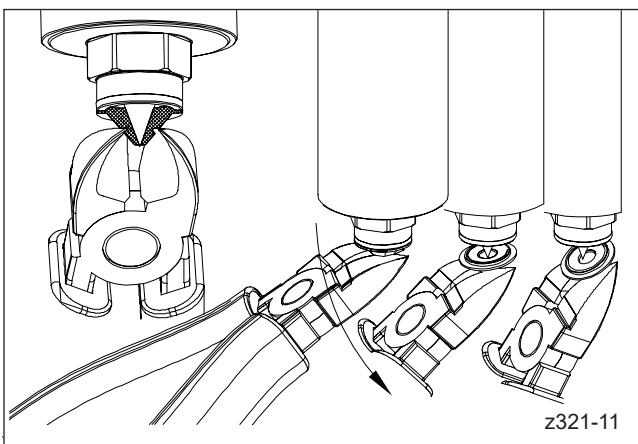
Removal of „cap“

Picture 40: Removal of cap

1. Precondition: the hot runner system is already filled with the new material!
2. Switch off the hot runner. Let the mould cooling stay switched on.
3. Dismantle the contour plate in cold condition.
By doing this the nozzle tips become accessible.
4. Switch the hot runner on again.
5. As soon as the cap, the area of frozen plastic between nozzle tip and gate, starts to melt partially around the tip it can be removed by using a side cutter.
Close the side cutter only so far that the cap can be pulled off. Closing it too far and with too much pressure can damage the heat conductive tip or the valve pin if a valve gate system is used.
6. Remaining material residues at the nozzle tip can be removed by using a wire brush (soft wire, see chapter „5.3.1 Tools and operating materials“).
7. Switch off the hot runner. Let the mould cooling stay switched on.
8. Install the contour plate in cold condition.
9. Switch on the hot runner.
10. After processing temperature is reached start moulding.

6.4 Instructions for the operation of valve gate systems



NOTE!

Use of gate exchange inserts

When using gate exchange inserts it must be ensured that the valve pin is only operated when the hot runner system is filled with melt.

When operating the valve pin in an unfilled system the gate exchange inserts can be pulled out of their fit and tilted when moving the valve pin backwards. This causes damage in the gating geometry.

When valve pins are operated in an unfilled system a clamping device must be provided in order to prevent the gate exchange inserts from being pulled out. Suitable solutions are the use of flat headed cylinder screws, clamping sleeves or retaining rings. Depending on the available installation space EWIKON can recommend a suitable clamping version.

In general the start-up of valve gate systems is carried out analogous to other externally heated systems. (see chapter „6.3.1 First-time start-up and filling of a HPS III hot runner system“ and „6.3.2 Start-up of an already filled HPS III hot runner system“). However, when operating valve gate systems some additional instructions must be followed:

- In order to check the valve pin length mould and hot runner must have reached their operating temperature.
- Valve pin movements must be carried out at operating temperature only

Pneumatic drive:

- Pneumatic pressure: see chapter „3.3 Hydraulic / pneumatic specifications (drive units)“.
- It is recommended to lubricate the compressed air with fully synthetic oil. The amount (drops/hour) depends on the number of cavities and the nozzle size.
- Example: valve gate system with 6 mm flow channel, 24-drop: 2 drops/hour (worth 12 drops/1000 liters of compressed air)

Hydraulic drive:

- To prevent thermal decomposition of the hydraulic oil the drive unit is equipped with a direct (screwed-on drive unit) or indirect (e.g. cooling channels in the clamping plate) water cooling. It must be ensured that the backflow temperature of the water does not exceed 85 °C.
- The system must only be heated when the mould cooling is switched on.
- Hydraulic pressure: see chapter „3.3 Hydraulic / pneumatic specifications (drive units)“.

Electric drive:

- The maximum permissible environmental temperature for the drive units is 70 °C (158 °F).
- Actuation of the drive units only when the hot runner system has reached set temperature.

Please make sure that the supply channels have a sufficient size. If possible, the diameter should be between 8 mm and 10 mm. Especially when using the valve gate as system nozzle a balanced supply channel layout should be provided.

6.4.1 Machine downtimes > 5 minutes of systems with HPS III-S / pro SHOT nozzles (system / single tip / single cavity)

- When processing sensitive materials (e.g. POM) purge with a neutral material (natural material, not coloured, e.g. polypropylene) before shutting down the machine.
- If maintenance work on mould inserts is planned, the valve pins must be moved to the rear position (gate open).
- For machine downtimes of more than 5 minutes the temperature of the hot runner system should be decreased (50°C - 60°C below processing temperature) in order to avoid thermal degradation of the material in the system.
- The injection moulding machine should feature a signal input and output to read and send error messages from and to the hot runner controller.
- Modern hot runner controllers feature an automatic decreasing function.

6.4.2 Dismantling the mould after the end of production / dismantling the hot runner

- Please observe the instructions in chapter 6.4.1 before dismantling.
- When dismantling the mould from the machine or when disassembling the hot runner system the valve pins should always be moved into their back position (gate open) in order to prevent them from being damaged. The valve pin can then not be damaged during installation and removal. If no maintenance is planned, the valve pins can remain in the front position (gate closed).
- If the hot runner should be removed from the mould, the valve pins must be moved to the rear position (gate open).
- Before dismantling the mould or disassembling the hot runner system, all hot runner components must have reached ambient temperature. For this the mould cooling should stay switched on for a sufficient time after the heaters for nozzles and manifold have been switched off.

6.5 Possible malfunctions

6.5.1 Troubleshooting

Error	Possible cause / measure
Temperature of control zone exceeds set temperature	Check if the thermocouple and power connections are allocated correctly (heat up each zone separately).
Controller indicates broken thermocouple. No temperature value is displayed	Check thermocouple at the nozzle and/or thermocouple cable and controller respectively.
Thermocouple indicates a temperature value too low	Jammed thermocouple (temperature at the position in the mould where it is jammed is displayed, normally between mould and room temperature)
Thermocouple indicates wrong temperature value	Wrong type of thermocouple allocated in the controller
Thermocouple indicates value zero	Thermocouple reverse-poled, check thermocouple circuit
Burns on part in one cavity within a multi-cavity mould	Check nozzle (check and compare voltage values of all nozzles at a given current).
Short decrease or increase in temperature (temperature fluctuations)	<ul style="list-style-type: none"> • Power or thermo cables do not have proper contact. • Humidity in the heater
Nozzle does not heat up properly	<ul style="list-style-type: none"> • Check assembly geometry of the hot runner • Check resistance of the concerned heating zone and the thermocouple
Nozzles are drooling	<ul style="list-style-type: none"> • Temperature of nozzles too high • Increase the machine nozzle bore to 8 - 10 mm or increase decompression. • Gating point too large
Hot runner leakage	<ul style="list-style-type: none"> • No sufficient preload • Fits used for sealing of the system are not OK

Chart 11: Errors/Measures

7. Maintenance

7.1 Safety instructions



WARNING!

Hot surfaces / hot material (plastic melt)

Body burns by hot surfaces.

- Let the HPS III hot runner system and all components cool down completely to ambient temperature before starting maintenance work / disassembling. Never touch material leaking from the nozzle/the mould/the hot runner or the material inlet. Even material that seems to be cooled down already may still be hot inside the core and cause burns.
- Please make sure you wear your personal protective equipment (PPE)

PPE



7.2 Instructions for maintenance



NOTE!

Deferred, incomplete and improper maintenance work causes increased wear on single components of the HPS III hot runner system.

- Maintenance work must be carried out according to the maintenance schedule completely and within the indicated time intervals.
- Specific maintenance work must only be carried out by the qualified staff which is specified in the maintenance schedule.

In addition to the proper operation a careful maintenance is required in order to assure a long service life as well as a trouble-free function of the HPS III hot runner system. Beside inspection and repair this is a preventive measure to keep the HPS III hot runner system in perfect operating condition.

Please adhere to the time intervals indicated in the maintenance schedule.

It is recommended to document the maintenance work carried out in written form.

7.3 Maintenance schedule

Component/ function	Measure	Staff	Interval	Remark

Chart 12: Example for a maintenance schedule

7.4 Checklist for possible maintenance work

Action	Open system	Valve gate system
Check all components optically for defects	X	X
Check seal fitting diameter of the nozzle, check the runout precision	X	X
Check tip insert (note: nozzle tip one-piece or two-piece?)	X	X
Check all cables visually for defects	X	X
Check thermocouple measurements and compare with delivery status	X	X
Check heating measurements and compare with delivery status	X	X
Carry out insulation test (if available by using an electrical tester)	X	X
Check the gate for wear		X
Check the valve pin in the valve pin guide area at manifold height		X
Check the sealing element in the manifold If leakage: analysis of the cause - mouthpiece - valve pin seal - sprue bushing - between nozzle and manifold		X
Check drive units for function/tightness		X
Check all water circuits for flow and tightness	X	X

Afterwards, the instructions under „5.7 Checks after installation“ must be observed.

7.5 Installation / deinstallation of nozzle tips

7.5.1 Safety instructions



WARNING!

PPE

Hot surfaces / hot material (plastic melt)

Body burns by hot surfaces.

- Let the HPS III hot runner system and all components cool down completely to ambient temperature before starting maintenance work / disassembling. Never touch material leaking from the nozzle/the mould/the hot runner or the material inlet. Even material that seems to be cooled down already may still be hot inside the core and cause burns.
- Please make sure you wear your personal protective equipment (PPE)



CAUTION!

Pay attention to system temperature during installation/deinstallation

Damage to melt seal.

- The contour plate must only be installed and deinstalled when the hot runner system has cooled down.
- If the nozzle temperature is too high when the contour plate is installed/deinstalled the melt sealing can be damaged. This can cause leakage of the system.

Problems during deinstallation of nozzle tips

Damage of nozzle tips

- If a nozzle tip can not be screwed out use the controller to raise the nozzle temperature in steps.
- If the nozzle tip is still not screwable please contact the EWIKON customer service. See chapter „7.8 Instructions for service and repair“.

Cleaning of threads and sealing surfaces

Damage to sealing surfaces during installation.

- Threads and sealing surfaces must be checked on cleanliness and free movement.
- Clean sealing surfaces and threads by using suitable cleaning tools (best directly after deinstallation of nozzle tip when the plastic is still viscous). Appropriate cleaning tools (brushes, scraper) must be made of materials which are softer than the steel of the hot runner components (soft metals or brass), also see chapter „5.3.1 Tools and operating materials“. Hereby, the sealing surfaces and threads can not be damaged during the cleaning process.

7.5.2 General information

The installation / deinstallation procedure for nozzle tips described in the following is valid for HPS III-S nozzles for front and standard installation as well as for HPS III-SXE single tips.

The nozzle tip exchange for L2X Drop-in hot runner systems is carried out analogous to a HPS III system. If the nozzle tip is installed/deinstalled while the L2X system is not installed in a mould it has to be fixed by using clamps or screw clamps.

One-piece nozzle tips

One-piece nozzle tips consist of the nozzle tip and a belonging part which is permanently connected with the nozzle tip and can not be separated.

One piece nozzle tips have only one item number (example: pos. 1.7, pos. 1.8 or pos. 1.9).

Two-piece nozzle tips

Two-piece nozzle tips consist of the nozzle tip (pos.1.3) and another component like for example a nosepiece (pos. 1.4), screw-on gate bushes (pos. 1.5) or extended screw-on gate bushes (pos. 1.6).

Two-piece nozzle tips always have a separate item number for each of their components.

Tipp:

In case that a cleaning of the flow channel of the nozzle is required EWIKON offers a maintenance mouthpiece with drill guide. See chapter „5.3.1 Tools and operating materials“.

The maintenance mouthpiece is installed after the tip insert has been removed (replaces the tip insert). It allows the precise insertion of a drill bit to remove most of the frozen plastic in the flow channel. The diameter of the drill bit should be 1/10 mm smaller than the flow channel diameter of the nozzle. Afterwards, remaining residues can be removed by using a soft wire brush (see chapter „5.3.1 Tools and operating materials“).

7.5.3 Versions of nozzle tips, nosepieces and screw-on gate bushes

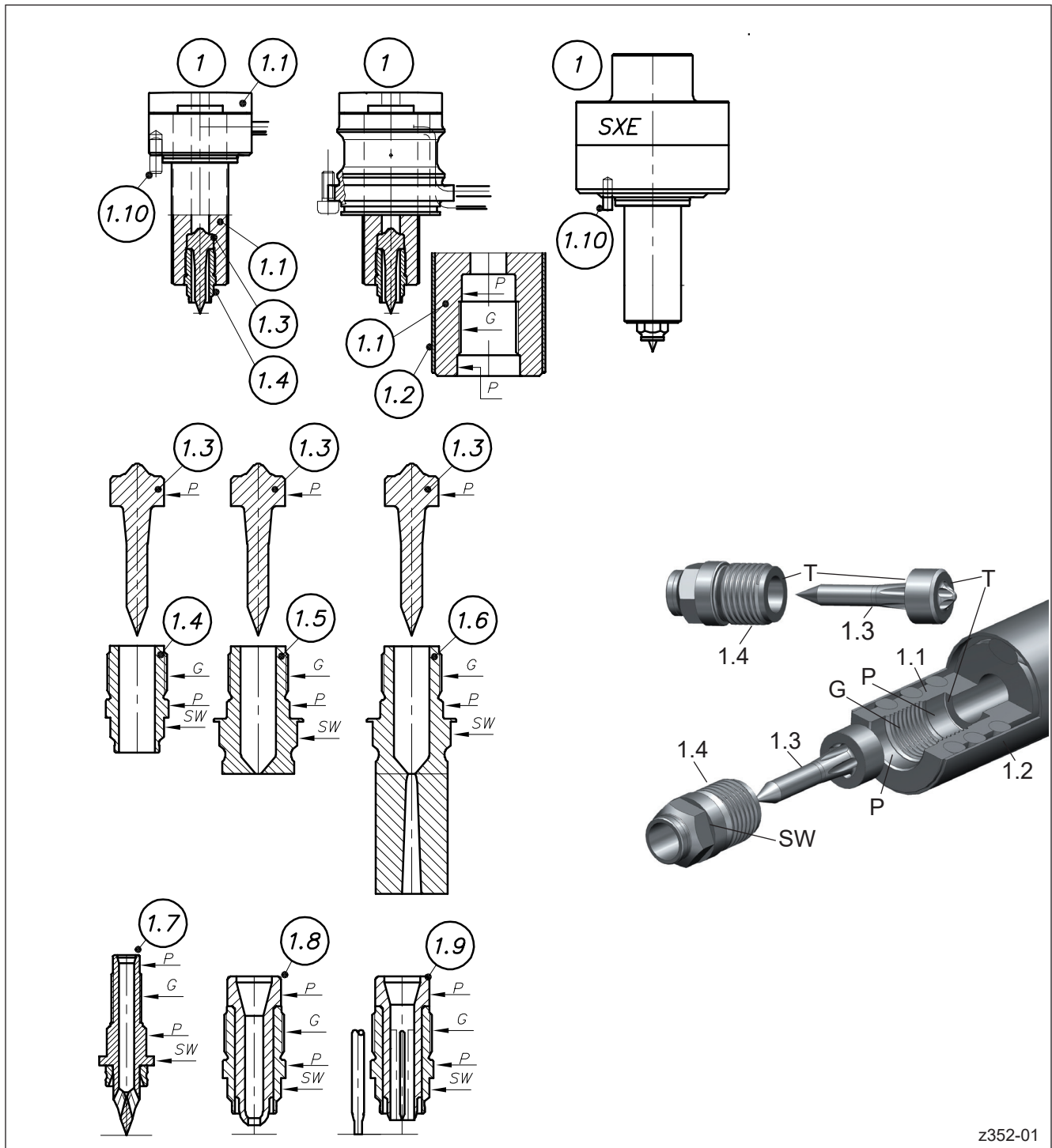

z352-01

Picture 41: Overview of the different versions of nozzle tips, mouth pieces and screw-on gate bushes

Pos. 1 Example: HPS III-S / pro SHOT nozzle
for standard installation
for front installation
HPS III-SXE single tip

Pos. 1.1 Pressure tube with thread (G) and fits (P)

Pos. 1.2 Protective tube

Pos. 1.3 Nozzle tip

Pos. 1.4 Mouthpiece

Pos. 1.5 Screw-on gate bush

Pos. 1.6 Extended screw-on gate bush

Pos. 1.7 Nozzle tip with sealing ring (one-piece)

Pos. 1.8 Nozzle tip with nosepiece (one-piece)

Pos. 1.9 Nozzle tip with nosepiece (one-piece)

Pos. 1.10 Dowel pin (ISO 8735, lock against rotation)

G Thread

P Fit

SW Width across flats

T Surfaces for blueing

7.5.4 Exchange of nozzle tips with nozzle installed in the mould

Standard installation

An exchange of nozzle tips must only be carried out when the nozzle is locked against rotation by a dowel pin in the mould. Otherwise the heater or the thermocouple may be torn off.

Attention:

When HPS III-S nozzles with flow channel \varnothing 3 and 4.5 mm for standard installation are used the installation of a dowel pin is not possible. Thus, the nozzle tips can not be exchanged with the nozzle installed in the mould.

Furthermore, a tip exchange inside the mould for HPS III-SXE single tips is only possible when the nozzle is fixed in the clamping plate with the locating ring. Otherwise it may fall out and be damaged.

Front installation

A nozzle tip exchange for nozzles for front installation which are screw connected to the mould is possible without a lock against rotation.

7.5.5 Exchange of nozzle tips outside the mould

Clamping of nozzle in a vice

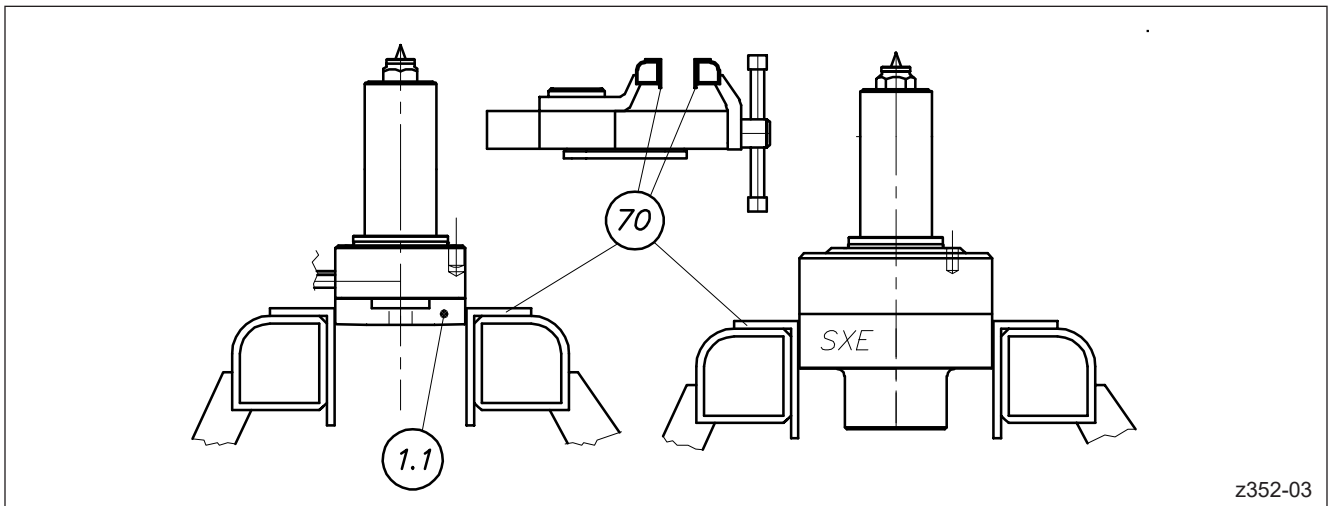

Picture 42: Clamping of a deinstalled HPS III nozzle in a vice



CAUTION!

Clamping of nozzle in a vice

The nozzle must be clamped in the indicated areas only to avoid damage.

If it is necessary to heat up the nozzle to deinstall the nozzle tip the vice must be grounded.

Exchange of nozzle tips outside the mould

To exchange a nozzle tip outside the mould a vice is required. Protective jaws (pos. 70, preferably made from aluminium), must be used to avoid damage to the nozzle.

The nozzle must always be clamped at the pressure tube (pos. 1.1). A HPS III-SXE single tip is clamped at the nozzle body (see picturePicture 42).

7.5.6 Deinstallation of one-piece nozzle tips

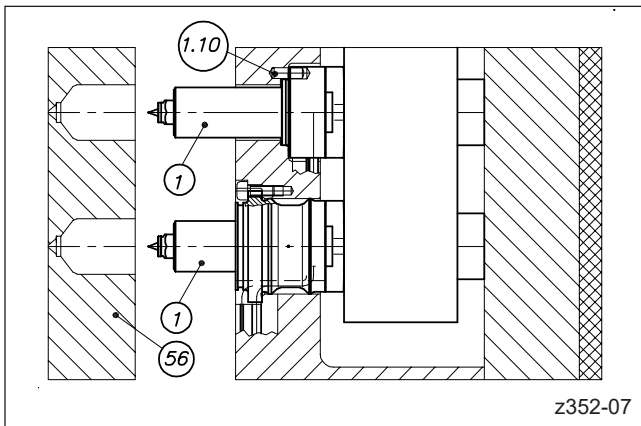

Picture 43: Deinstallation of contour plate (HPS III-S / pro SHOT nozzle)

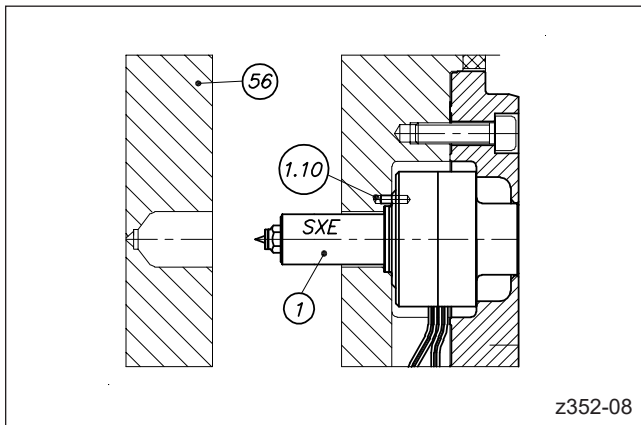

Picture 44: Deinstallation of contour plate (HPS III-SXE single tip)

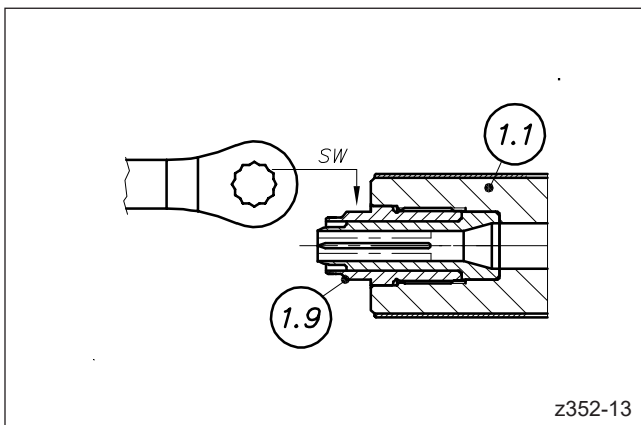

Picture 45: Unscrewing of nozzle tip



WARNING!



Sharp edges and heavy components

- Cut injuries to body and extremities, mainly to the hands.
- Crushing of fingers or hand.

Hot surfaces

Burns to the body caused by hot surfaces.



NOTE!

When nozzle tips of HPS III nozzles or HPS III-SXE single tips are exchanged while the nozzle is installed in the mould a lock against rotation (dowel pin, pos 1.10) must be installed.

1. To carry out a nozzle tip exchange while the nozzle is installed inside the mould deinstall the contour plate (pos. 56) in cold condition. For a nozzle tip exchange outside the mould clamp the nozzle in a vice (see Picture 42) and connect it to a controller.
 2. Heat up nozzle (pos. 1) to 220 °C (428 °F).
 3. Unscrew the nozzle tip (pos. 1.9) from the pressure tube (pos. 1.1) by using a ring wrench (see chapter „5.3.1 Tools and operating materials“).
- Important: Before deinstalling a valve gate nozzle tip the valve pin must be moved to position „open“.**
4. Clean the nozzle tip (pos. 1.9) thoroughly by using a brass wire brush (see chapter „5.3.1 Tools and operating materials“). If necessary use a hot air gun with a maximum temperature of 460 °C (860 °F).
 5. Check all surfaces for cleanliness. All contact surfaces at the pressure tube (pos. 1.1) and the nozzle tip (pos. 1.9) should be metallic bright.

7.5.7 Installation of one-piece nozzle tips

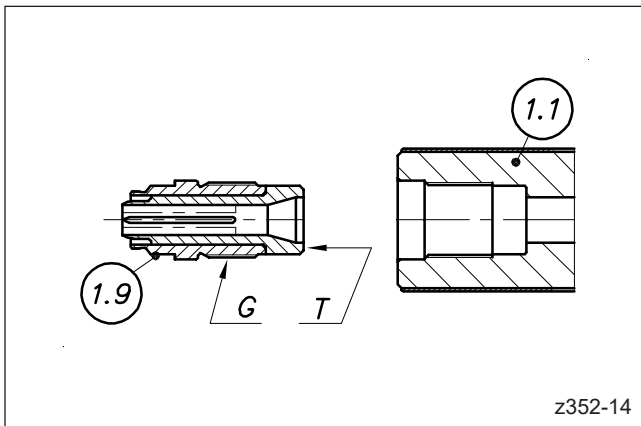

Picture 46: Installation of nozzle tip

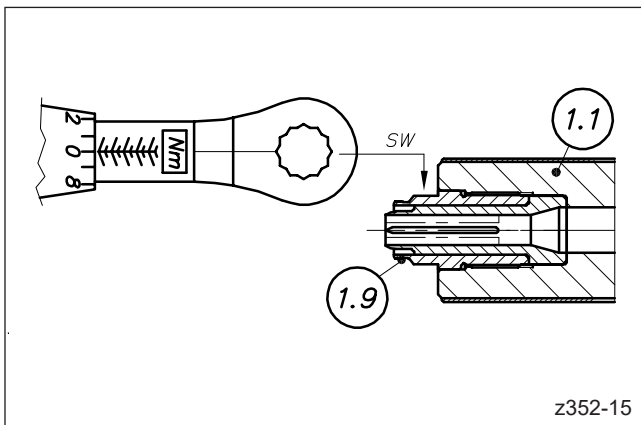

Picture 47: Tightening of nozzle tip



WARNING!



Sharp edges and heavy components

- Cut injuries to body and extremities, mainly to the hands.
- Crushing of fingers or hand.

Hot surfaces

Burns to the body caused by hot surfaces.



NOTE!

When nozzle tips of HPS III nozzles or HPS III-SXE single tips are exchanged while the nozzle is installed in the mould a lock against rotation (dowel pin, pos 1.10) must be installed.

1. The contour plate must be deinstalled.
2. Apply a thin and even coat of engineer's blue (see chapter „5.3.1 Tools and operating materials“) to the contact surface of the cold nozzle tip (pos. 1.9 / surface T).
3. Apply high temperature installation paste (see chapter „5.3.1 Tools and operating materials“) to the thread of the nozzle tip (pos. 1.9 / surface G).
Attention: Surfaces where engineer's blue is applied must not get in contact with the installation paste because otherwise the transfer of the blue is falsified.
4. Screw the nozzle tip (pos. 1.9) into the pressure tube (pos. 1.1) and tighten with the matching tightening torque. See chapter „9.3 Tightening torques for tip inserts“.

Important: Before installing a valve gate nozzle tip the valve pin must be moved to position „open“.

5. Unscrew and deinstall the nozzle tip again and check the transfer of the blue. The surface T between nozzle tip (pos. 1.9) and pressure tube (pos. 1.1) must show an even ring-shaped transfer of the blue.
6. Clean all surfaces from engineer's blue.
7. Heat up nozzle to 220 °C (428 °F).
8. Apply high temperature installation paste to the thread of the nozzle tip (surface G) again. Install nozzle tip (pos. 1.9) again as described under 4.
9. Let the nozzle cool down before carrying out further work steps.

7.5.8 Deinstallation of two-piece nozzle tips

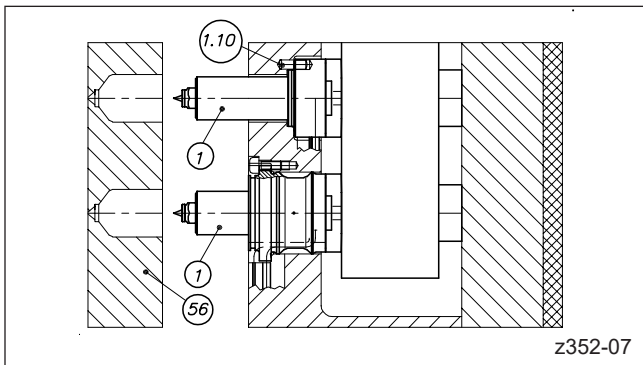

Picture 48: Disassembly of contour plate (HPS III-S / pro SHOT nozzle)

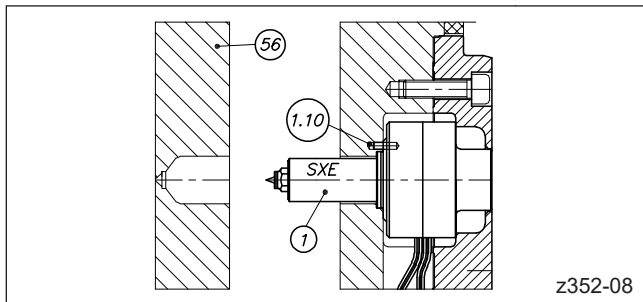

Picture 49: Disassembly of contour plate (HPS III-SXE single tip)

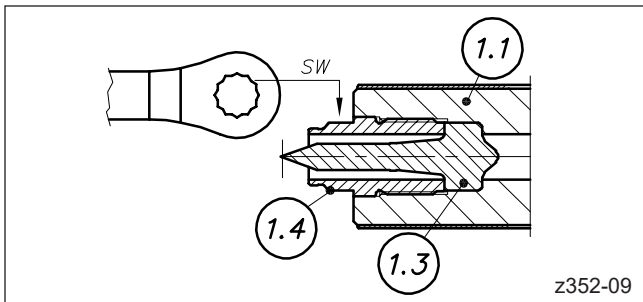

Picture 50: Unscrewing of nose piece

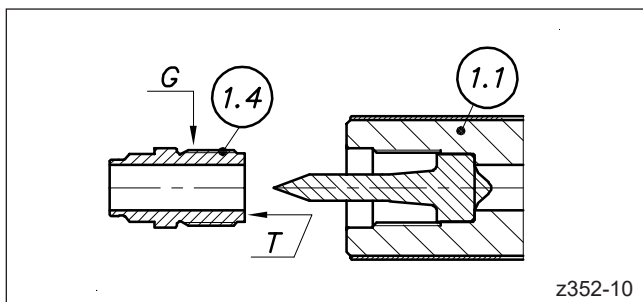

Picture 51: Nose piece removed

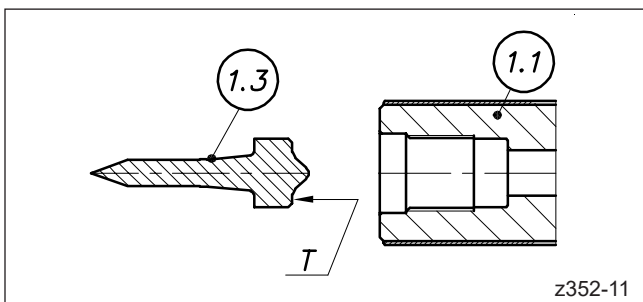

Picture 52: Disassembly of nozzle tip



WARNING!



Sharp edges and heavy components

- Cut injuries to body and extremities, mainly to the hands.
- Crushing of fingers or hand.

Hot surfaces

Burns to the body caused by hot surfaces.



NOTE!

When nozzle tips of HPS III nozzles or HPS III-SXE single tips are exchanged while the nozzle is installed in the mould a lock against rotation (dowel pin, pos 1.10) must be installed.

1. To carry out a nozzle tip exchange while the nozzle is installed inside the mould deinstall the contour plate (pos. 56) in cold condition. For a nozzle tip exchange outside the mould clamp the nozzle in a vice (see Picture 42) and connect it to a controller.
2. Heat up nozzle (pos. 1) to 220 °C (428 °F).
3. Unscrew the nosepiece (pos. 1.4) from the pressure tube (pos. 1.1) by using a ring wrench (see chapter „5.3.1 Tools and operating materials“).
4. Grip the shaft of the nozzle tip (pos. 1.3) with a pair of pliers and pull it out of the pressure tube with slight rotary motions. Proceed carefully to avoid damage.
5. Clean nozzle tip (pos. 1.3) and nosepiece (pos. 1.4) thoroughly by using a brass wire brush (see chapter „5.3.1 Tools and operating materials“). If necessary use a hot air gun. The temperature must not exceed 400 °C (752 °F).
6. Check all surfaces for cleanliness. All contact surfaces at the pressure tube (pos. 1.1), nozzle tip (pos. 1.3) and nosepiece (pos. 1.4) should be metallic bright.

7.5.9 Installation of two-piece nozzle tips

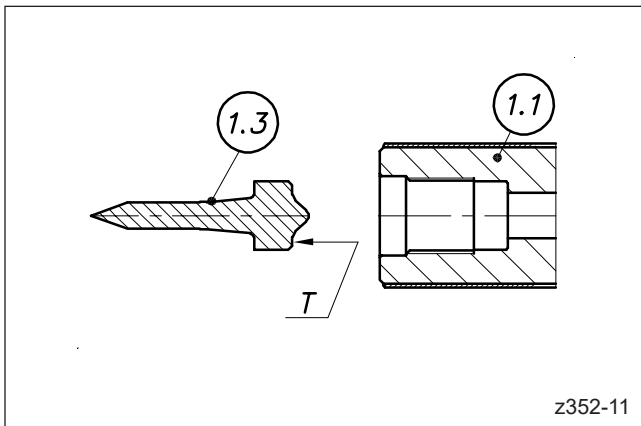

Picture 53: Installation of nozzle tip

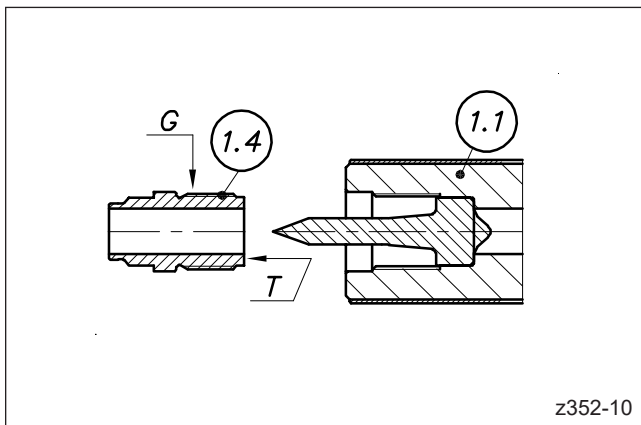

Picture 54: Nozzle tip installed

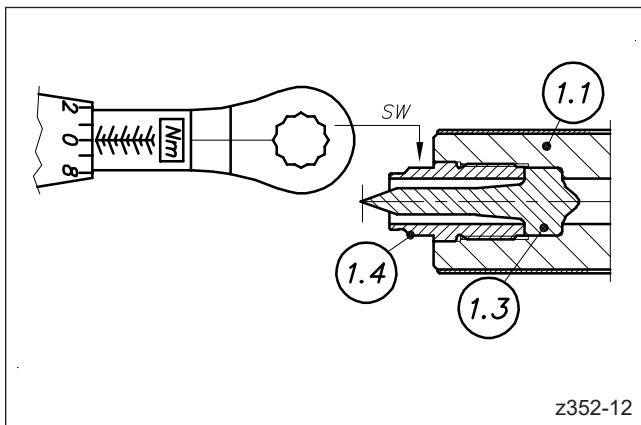

Picture 55: Tightening of nozzle tip with matching torque



WARNING!



Sharp edges and heavy components

- Cut injuries to body and extremities, mainly to the hands.
- Crushing of fingers or hand.

Hot surfaces

Burns to the body caused by hot surfaces.



NOTE!

When nozzle tips of HPS III nozzles or HPS III-SXE single tips are exchanged while the nozzle is installed in the mould a lock against rotation (dowel pin, pos 1.10) must be installed.

1. The contour plate must be deinstalled.
2. Apply a thin and even coat of engineer's blue (see chapter „5.3.1 Tools and operating materials“) to the contact surface (surfaces T) of the cold nozzle tip (pos. 1.3) and the nosepiece (pos. 1.4).
3. Slide the nozzle tip (pos. 1.3) carefully and without tilting into the pressure tube (pos. 1.1) up to the stop.
4. Apply high temperature installation paste (see chapter „5.3.1 Tools and operating materials“) to the thread of the nosepiece (pos. 1.4 / surface G).
Attention: Surfaces where engineer's blue is applied must not get in contact with the installation paste because otherwise the transfer of the blue is falsified.
5. Slide the nosepiece (pos. 1.4) carefully over the nozzle tip, screw it into the pressure tube and tighten with the matching tightening torque. See chapter „9.3 Tightening torques for tip inserts“.
6. Unscrew and deinstall nosepiece (Pos. 1.4) and nozzle tip (pos. 1.3) again and check the transfer of the blue. The surfaces T between nozzle tip (pos. 1.3) and pressure tube (pos. 1.1) as well as between nosepiece (pos. 1.4) and nozzle tip (pos. 1.3) must show an even ring-shaped transfer of the blue.
7. Clean all surfaces from engineer's blue.
8. Heat up nozzle to 220 °C (428 °F).
9. Apply high temperature installation paste to the thread of the nosepiece (surface G) again. Install nozzle tip (pos. 1.3) and nosepiece (pos. 1.4) again as described under 3. and 5. First, screw in the nosepiece (pos. 1.4) hand-tight (< tightening torque) and wait until both parts have reached the nozzle temperature. Then tighten with the matching tightening torque. See chapter „9.3 Tightening torques for tip inserts“.
10. Let the nozzle cool down before carrying out further work steps.

7.6 L2X (valve gate) nozzles – exchange of thermocouple

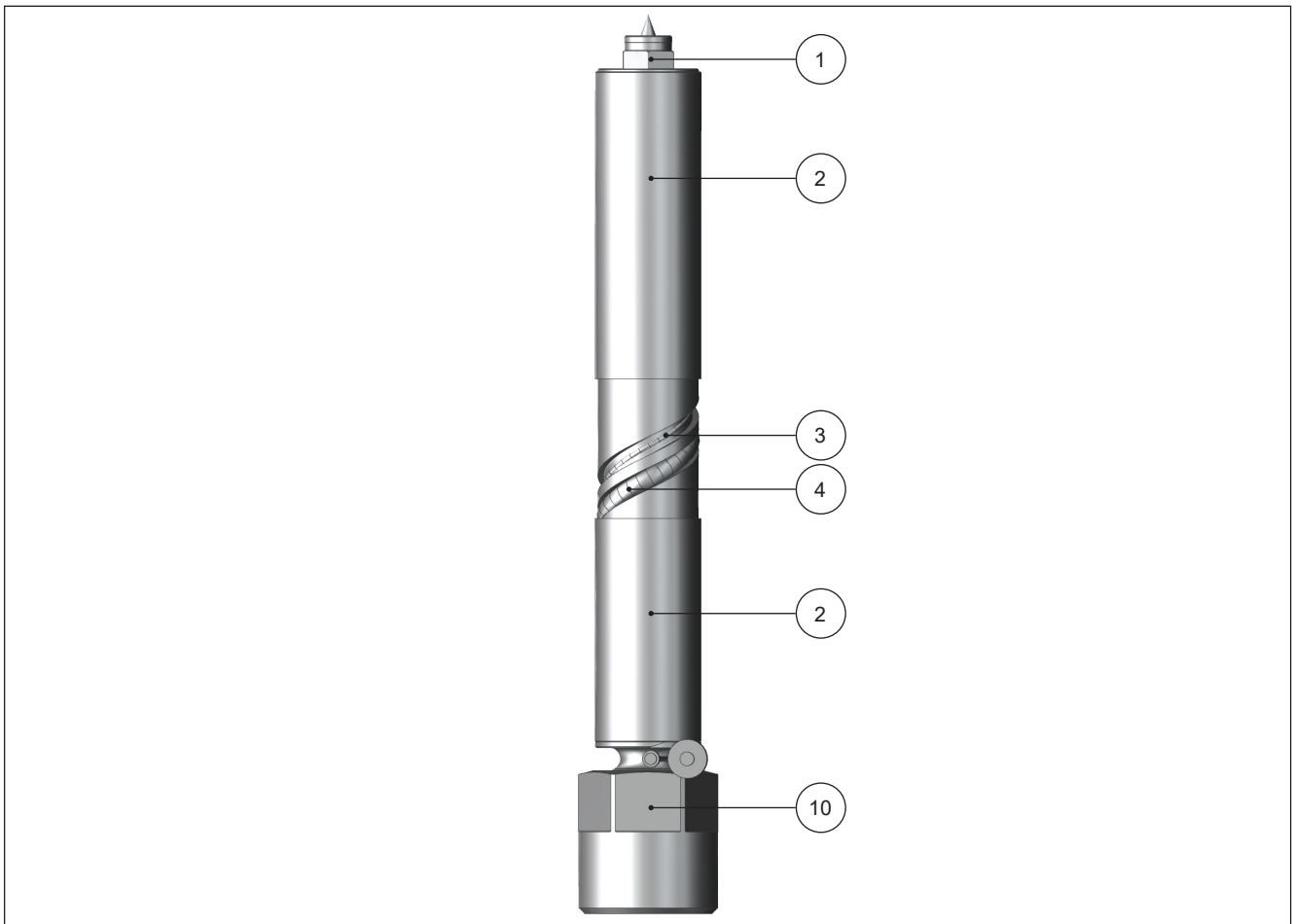

Picture 56: L2X Düse, 6mm

Pos. 1	Tip insert
Pos. 2	Protective tube
Pos. 3	Thermocouple
Pos. 4	Heater
Pos. 10	Connecting nut



HAZARD!

Connected power supply during installation

Risk of deadly electric shock or severe injuries due to live components.

- The hot runner system and the mould have to be disconnected from the voltage source during installation.



WARNING!



Sharp edges and heavy components

- Cut injuries to body and extremities, mainly to the hands.
- Crushing of fingers or hand.

Control of live components before installation

The electrical equipment of the hot runner system should be checked, especially those areas which will no longer be accessible after installation. Physical injuries such as an electric shock can be prevented that way.

Please check

- if cables are kinked or squeezed.
- if cable insulations are undamaged.

Check function of thermocouple

- Check resistance of thermocouple before and after installation to ensure that it has not been damaged during installation.

L2X (valve gate) nozzles – exchange of thermocouple

Picture 58: Clamp the nozzle



Picture 59: Pull off the protective tube



Picture 57: Disassemble the thermocouple

1. Clamp the nozzle in the vice at the connecting nut.

2. Disassemble the protective tube. It may be necessary to use two screwdrivers as levers to untighten the protective tube. If necessary apply WD 40 penetrating oil (see chapter „5.3.1 Tools and operating materials“) or heat moderately from the outside.

3. The nozzle heater and the thermocouple are connected by a protective hose and cable ties. Disconnect the thermocouple, disassemble the broken thermocouple from the cutout starting at the base of the pressure tube and pull it out of the bore in the nozzle.

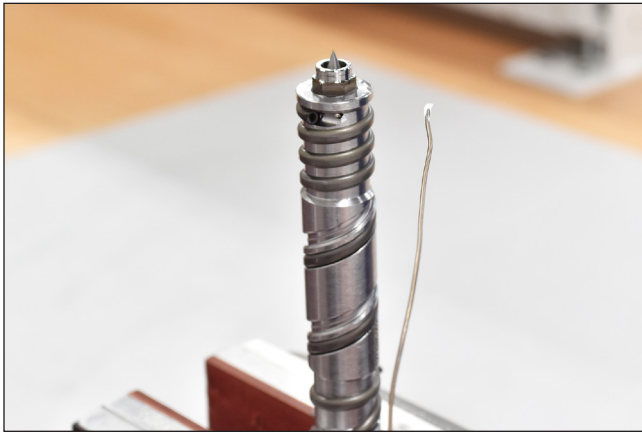
L2X (valve gate) nozzles – exchange of thermocouple

Picture 60: Coated tip of thermocouple



Picture 61: Installation of the new thermocouple

4. Coat the tip of the new thermocouple with heat transferring paste (see chapter „5.3.1 Tools and operating materials“) and insert it into the bore in the nozzle as far as it will go.
5. Bend the thermocouple carefully and wind it along the heater. At the same time slide the protective tube over the pressure tube to fix the already positioned part of the thermocouple.
6. Check functioning of the new thermocouple by heating up the nozzle with a controller.
7. For notes for installation of the nozzle please refer to chapter „5.5 Installation of L2X Drop-in hot runner systems“.

7.7 Deinstallation / exchange of valve pins

7.7.1 Drive units with pistons - deinstallation und exchange of valve pins

The procedure for deinstallation of the valve pin as described in the following is valid for the following drive unit versions:

- Drive unit integrated in clamping plate (version 1)
- Drive unit integrated in clamping plate (version 2)
- Drive unit placed on manifold (coupled)
- Drive unit placed on manifold (screwed-on) (version 1)
- Drive unit placed on manifold (screwed-on) (version 2)

The example shows a drive unit integrated in the clamping plate.

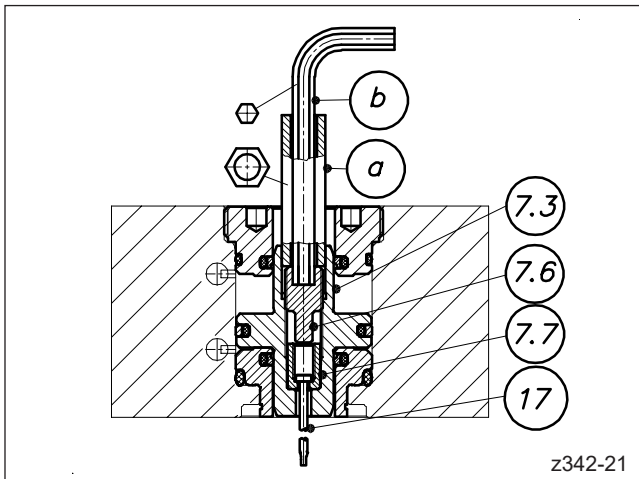

Picture 63: Dismantling of screw by using a tubular hexagon spanner



HAZARD!

Connected power supply during installation

Risk of deadly electric shock or severe injuries due to live components.

- The hot runner system and the mould have to be disconnected from the voltage source during installation.



WARNING!



Pressurised systems

During installation all hydraulic or pneumatic supply lines must be depressurised.

- Injuries caused by flying parts or "whipping" hoses.
- Injuries to eyes caused by escaping pressurised liquids.

Hot surfaces

Burns to the body caused by hot surfaces.

1. Switch on the mould cooling and heat up the hot runner system to processing temperature.
2. Insert tubular hexagon spanner (pos. a, see chapter „5.3.1 Tools and operating materials“) into the hexagonal cutout in the piston (pos. 7.3) and hold it in position by using a wrench to avoid rotation of the piston (pos. 7.3).
3. Insert the allen key (pos. b, see chapter „5.3.1 Tools and operating materials“) through the tubular hexagon spanner (pos. a) to unscrew and to dismantle the screw (pos. 7.6).

Drive units with pistons - deinstallation und exchange of valve pins

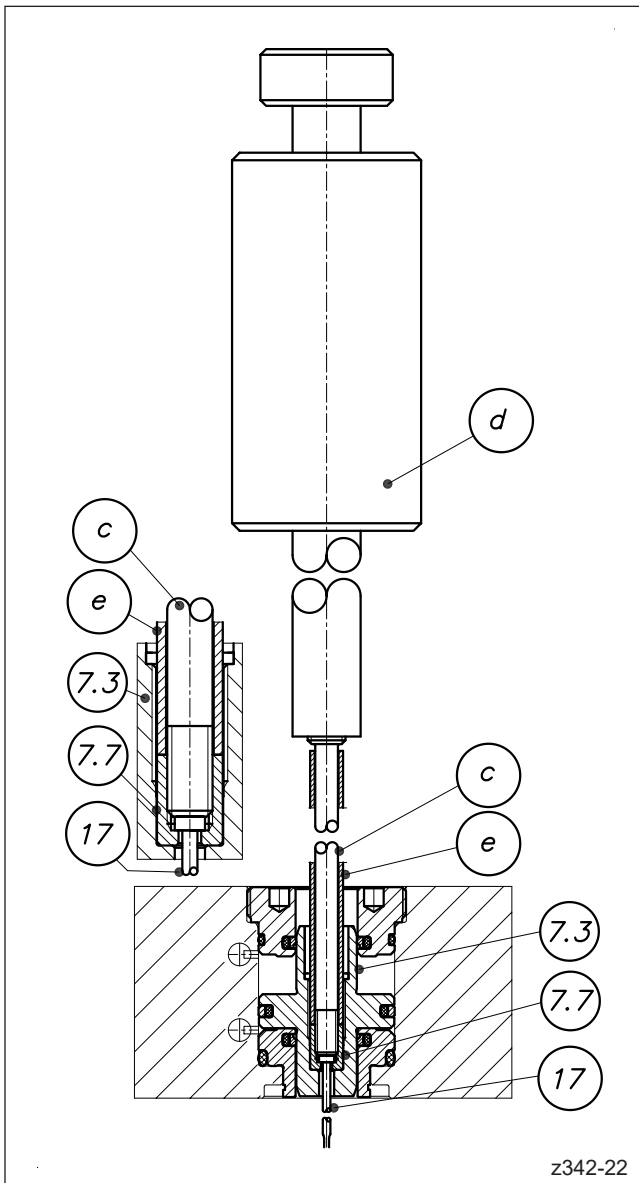

Picture 64: Screw in threaded rod to disassemble valve pin retainer and valve pin

4. After unscrewing the screw the valve pin retainer (pos. 7.7) becomes visible. Screw a threaded rod (pos. c) into the valve pin retainer and connect it with a striking weight (pos. d, see chapter „5.3.1 Tools and operating materials“).
5. Use the striking weight to untighten the valve pin retainer. Then pull out the valve pin retainer with valve pin (pos. 17) carefully and without tilting.
6. Replace the valve pin with the new one.
7. Screw the threaded rod into the valve pin retainer again.
8. Insert the new valve pin (pos. 17) carefully and without tilting. Apply axial load only. Tilting or bending caused by lateral load must be avoided. Slowly push the valve pin through the manifold and the valve pin guide in the tip insert of the nozzle until the valve pin retainer (pos. 7.7) sits at the bottom of the drive unit.
9. Slide the disassembly sleeve (pos. e, see chapter „5.3.1 Tools and operating materials“) over the threaded rod (pos. c, see chapter „5.3.1 Tools and operating materials“) and use it to fix the valve pin retainer with gentle pressure. Unscrew the threaded rod and remove the disassembly sleeve.
10. Screw the screw (pos. 7.6) in again by using the allen key (pos. b, see chapter „5.3.1 Tools and operating materials“) and the tubular hexagon spanner (pos a, see chapter „5.3.1 Tools and operating materials“). Tighten with matching torque. See chapter „9.5 Tightening torques for screws to fix the valve pin in the valve pin retainer“.

7.7.2 Electric drive unit with step motor – deinstallation and exchange of valve pins

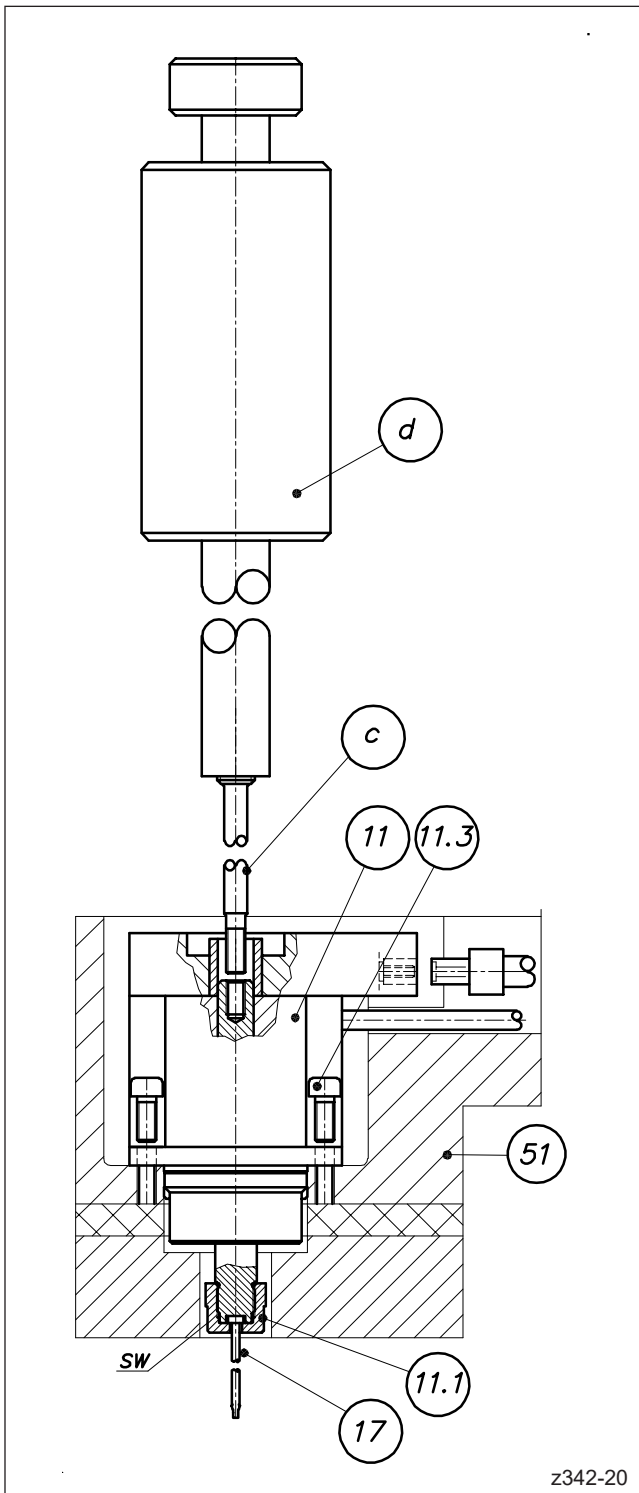

Picture 65: Deinstallation of valve pin



HAZARD!

Connected power supply during installation

Risk of deadly electric shock or severe injuries due to live components.

- The cold runner system and the mould have to be disconnected from the voltage source during installation.



WARNING!



Sharp edges and heavy components

- Cut injuries to body and extremities, mainly to the hands.
- Crushing of fingers or hand.

Control of live components before installation

The electrical equipment of the hot runner system should be checked, especially those areas which will no longer be accessible after installation. Physical injuries such as an electric shock can be prevented that way.

Please check

- if cables are kinked or squeezed.
- if cable insulations are undamaged.

Hot surfaces

Burns to the body caused by hot surfaces.

1. Disconnect the wiring of the drive unit.
2. Heat up the hot runner system to processing temperature.
3. Unscrew the socket head screws (pos. 11.3) of the electric drive unit. Screw a threaded rod (pos. c, see chapter „5.3.1 Tools and operating materials“) with striking weight (pos. d, see chapter „5.3.1 Tools and operating materials“) into the thread at the backside of the drive unit to to dismantle the drive unit from the clamping plate (pos. 51). Then pull out the drive unit (pos. 11) with valve pin retainer and valve pin carefully and without tilting.
4. Unscrew the valve pin retainer (pos. 11.1) with valve pin (pos. 17) from the drive unit (pos. 11) by using a wrench.
5. Pull the valve pin (pos. 17) carefully out the valve pin retainer.
6. For installation of the new valve pin and the drive unit please see chapter „5.5.11 Electric drive unit with step motor“.

7.7.3 Electric drive unit with servo motor – deinstallation and exchange of valve pins

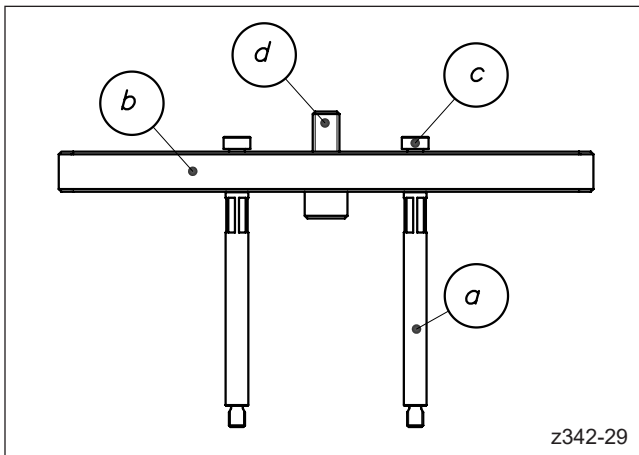

Picture 66: Disassembly device servo motor

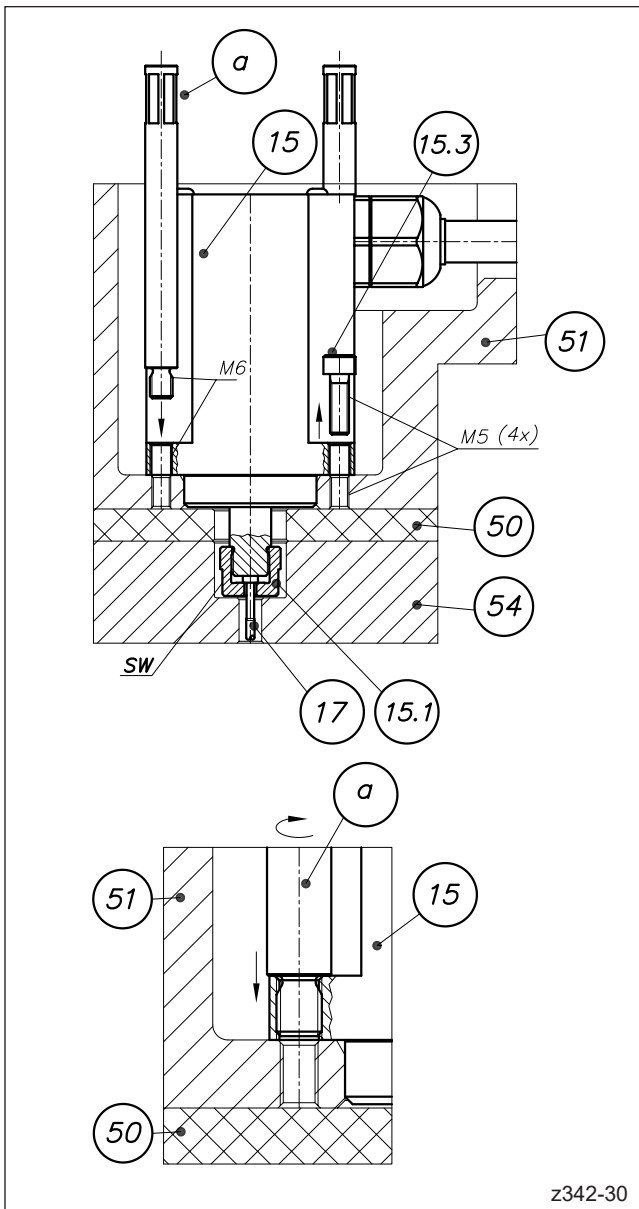

Picture 67: Screw in the bolts of the disassembly device



HAZARD!

Connected power supply during installation

Risk of deadly electric shock or severe injuries due to live components.

- The cold runner system and the mould have to be disconnected from the voltage source during installation.



WARNING!



Sharp edges and heavy components

- Cut injuries to body and extremities, mainly to the hands.
- Crushing of fingers or hand.

Control of live components before installation

The electrical equipment of the hot runner system should be checked, especially those areas which will no longer be accessible after installation. Physical injuries such as an electric shock can be prevented that way.

Please check

- if cables are kinked or squeezed.
- if cable insulations are undamaged.

Hot surfaces

Burns to the body caused by hot surfaces.

1. Disconnect the plug connection of the drive unit.
2. Heat up the hot runner system to processing temperature.
3. Unscrew and remove the socket head screws (item 15.3) of the electric drive unit.
4. Screw the two bolts (item a) of the disassembly device T00543 (item b, see chapter „5.3.1 Tools and operating materials“) into the servo motor housing at diagonally opposite positions and tighten hand-tight using an SW8 spanner (see Picture 67 and Picture 68).

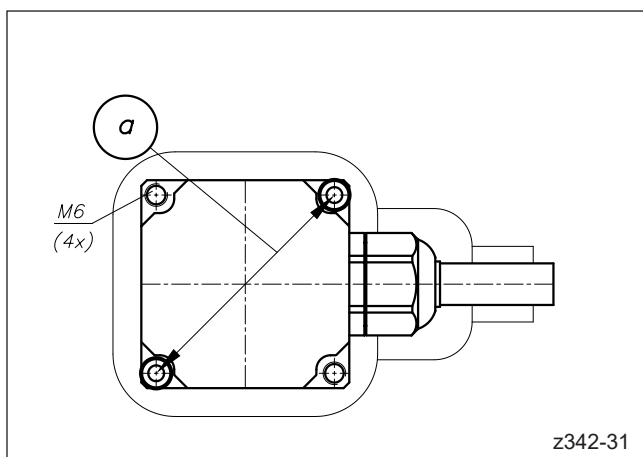

Picture 68: Screw in bolts diagonally

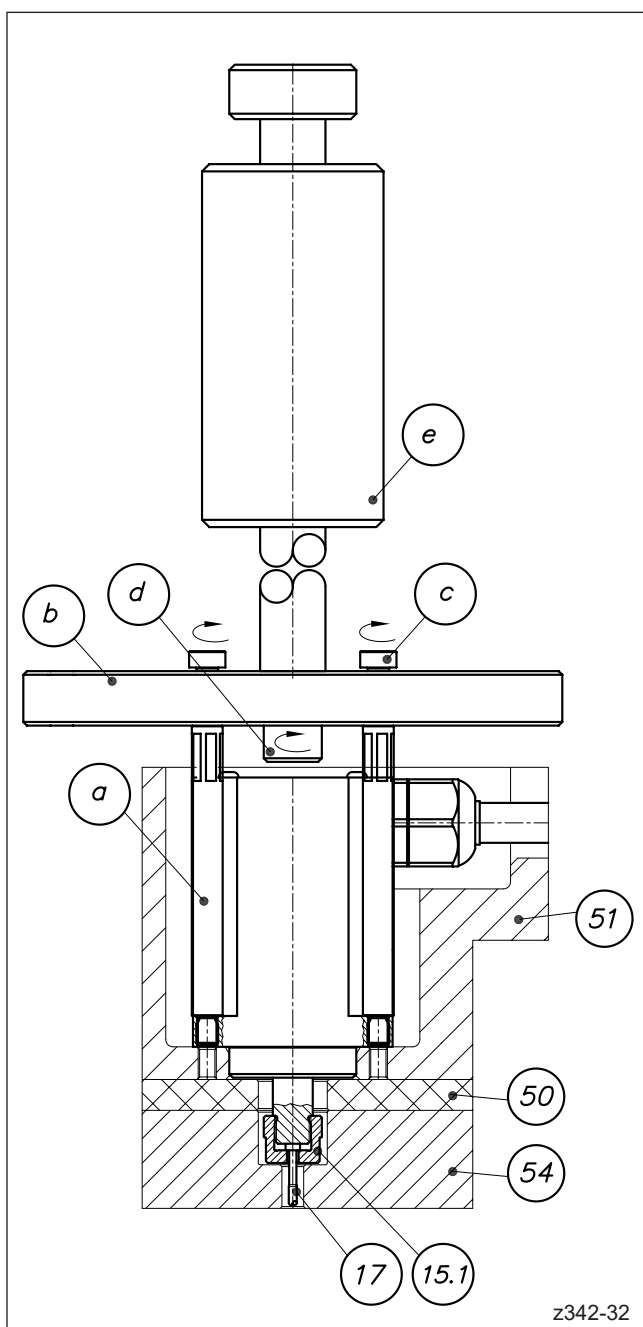

Picture 69: Screw on the disassembly device, loosen with striking weight

5. Screw the disassembly device to the bolts using the two corresponding shoulder fitting screws (item c) and tighten hand-tight. Position the M10 cylinder screw (item d) in the centre above the servo motor (Picture 69).
6. Attach an striking weight (item e, see chapter „5.3.1 Tools and operating materials“) to the socket head screw M10 and loosen the drive unit from the clamping plate with even, straight strikes without tilting it (Picture 69).
7. Carefully pull out the drive unit including valve pin holder (item 15.1) and valve pin (item 17) upwards without tilting.
8. Unscrew the valve pin holder with inserted valve pin from the drive unit using a spanner.
9. Carefully pull the old valve pin out of the valve pin holder.
10. Install the new valve pin and the electric drive unit as described in chapter „5.5.12 Electric drive unit with servo motor“.

7.8 Instructions for service and repair

- Only genuine spare parts must be used.
- When ordering spare parts please use the specifications given in the spare-parts lists.
- In case of service requests please always have the serial number, order number and type of the used hot runner system ready.

- **Service**
www.ewikon.com in the "Contact" menu, submenu "Sales network", "Your contact at EWIKON", "Service department"
E-Mail: service@ewikon.com

8. Decommissioning

8.1 Safety instructions



HAZARD!

Connected power supply during deinstallation

Risk of deadly electric shock or severe injuries due to live components.

- The hot runner components and the mould have to be disconnected from the voltage source during deinstallation.



WARNING!

Hot surfaces / hot material (plastic melt)

Body burns by hot surfaces.



- Let the HPS III hot runner system and all components cool down completely to ambient temperature before starting maintenance work / disassembling. Never touch material leaking from the nozzle/the mould/the hot runner or the material inlet. Even material that seems to be cooled down already may still be hot inside the core and cause burns.
- Please make sure you wear your personal protective equipment (PPE)



Escape of hydraulic liquid and pressurised air

Risk of injuries.

- All hydraulic or pneumatic supply lines must be depressurised.



NOTE!

- All operating materials and fluids must be emptied, collected and disposed in accordance with the local regulations.
- Follow the safety instructions for transport with lifting accessories (see chapter „5.1 Transport“).
- Only specialised staff is allowed to carry out any deinstallation work.

8.2 Instructions for disposal



NOTE!

Once disposed components must not be used again. EWIKON disclaims any responsibility for personal injuries and material damage resulting from re-use.

In case that no special arrangements regarding return or disposal were agreed with EWIKON the disassembled components have to be recycled after deinstallation:

- Scrap metallic materials.
 - Recycle plastic components and plastic waste from the production.
 - Dispose the remaining components sorted by their material properties.
 - Electronic scrap and electronic components are special waste and must be disposed by authorised specialised companies only.
 - With regard to the environmentally sound disposal of the deinstalled HPS III hot runner system the local regulations for waste disposal must be observed.
-

9. Tightening torques

9.1 Tightening torques for socket head screws

- Tighten socket head screws with the matching torques according to the following chart. All values are non-binding standard values for socket head screws with internal hexagon and standard metric thread complying with DIN EN ISO 4762.

All values were determined in accordance with the guideline VDI 2230 sheet 1:2014-12 which is based on the most frequently used torque controlled tightening method with normally 90% utilisation of the minimum yield strength $R_{p0,2}$. The values given are valid for socket head screws with property class 8.8, 10.9 and 12.9 with internal hexagon and standard metric thread complying with DIN EN ISO 4762 (replacement for DIN 912).

- The values are valid for clearance holes with tolerance "medium" complying with DIN EN 20273.
- The values are to be understood as maximum permissible tightening torques (without safety factor).
- Only calibrated tightening tools must be used.
(When the tightening method/ the tightening tool shows a greater variation (approx. $> \pm 5\%$) the required tightening torque M_A must be appropriately reduced to avoid overstressing (control test required). It must be considered that different tightening methods can show a different variation.)
- EWIKON generally recommends to use screws with property class 12.9 only.

Tightening torques for socket head screws

Thread	Lead	Width across flats AW	Property class	Maximum permissible tightening torque M_A at room temperature			
				Lubricated (High temperature installation paste, see chapter „5.3.1 Tools and operating materials“) $\mu_G=0.10$		Screws in as-delivered condition (slightly oiled) $\mu_G=0.14$	
				M_A [Nm]	M_A [ft·lb]	M_A [Nm]	M_A [ft·lb]
M3	0.5	2.5	8.8	1.12	0.83	1.41	1.04
			10.9	1.58	1.17	1.98	1.46
			12.9	1.90	1.40	2.37	1.75
M4	0.7	3	8.8	2.6	1.9	3.3	2.4
			10.9	3.9	2.9	4.8	3.5
			12.9	4.5	3.3	5.6	4.1
M5	0.8	4	8.8	5.2	3.8	6.5	4.8
			10.9	7.6	5.6	9.5	7.0
			12.9	8.9	6.6	11.2	8.3
M6	1.0	5	8.8	9.0	6.6	11.3	8.3
			10.9	13.2	9.7	16.5	12.2
			12.9	15.4	11.4	19.3	14.2
M7	1.0	6	8.8	14.8	10.9	18.7	13.8
			10.9	21.7	16.0	27.5	20.3
			12.9	25.4	18.7	32.2	23.7
M8	1.3	6	8.8	21.6	15.9	27.3	20.1
			10.9	31.8	23.5	40.1	29.6
			12.9	37.2	27.4	46.9	34.6
M10	1.5	8	8.8	43	32	54	40
			10.9	63	46	79	58
			12.9	73	54	93	69
M12	1.8	10	8.8	73	54	93	69
			10.9	108	80	137	101
			12.9	126	93	160	118
M14	2.0	12	8.8	117	86	148	109
			10.9	172	127	218	161
			12.9	201	148	255	188
M16	2.0	14	8.8	180	133	230	170
			10.9	264	195	338	249
			12.9	309	228	395	291
M18	2.5	14	8.8	259	191	329	243
			10.9	369	272	469	346
			12.9	432	319	549	405
M20	2.5	17	8.8	363	268	464	342
			10.9	517	381	661	488
			12.9	605	446	773	570
M22	2.5	17	8.8	495	365	634	468
			10.9	704	519	904	667
			12.9	824	608	1057	780
M24	3.0	19	8.8	625	461	798	589
			10.9	890	656	1136	838
			12.9	1041	768	1329	980

Chart 13: Tightening torques for socket head screws with standard metric thread according to DIN EN ISO 4762

9.2 Tightening torques for manifold screw connections and retaining screws

Thread	Tightening torque Lubricated (high temperature installation paste, see chapter „5.3.1 Tools and operating materials“)	
	M_A [Nm]	M_A [ft·lb]
M4	1.5	1.1
M6	5	3.7
M8	10	7.4

Chart 14: Tightening torques for manifold screw connections (for standard installation of nozzles) and retaining screws

9.3 Tightening torques for tip inserts

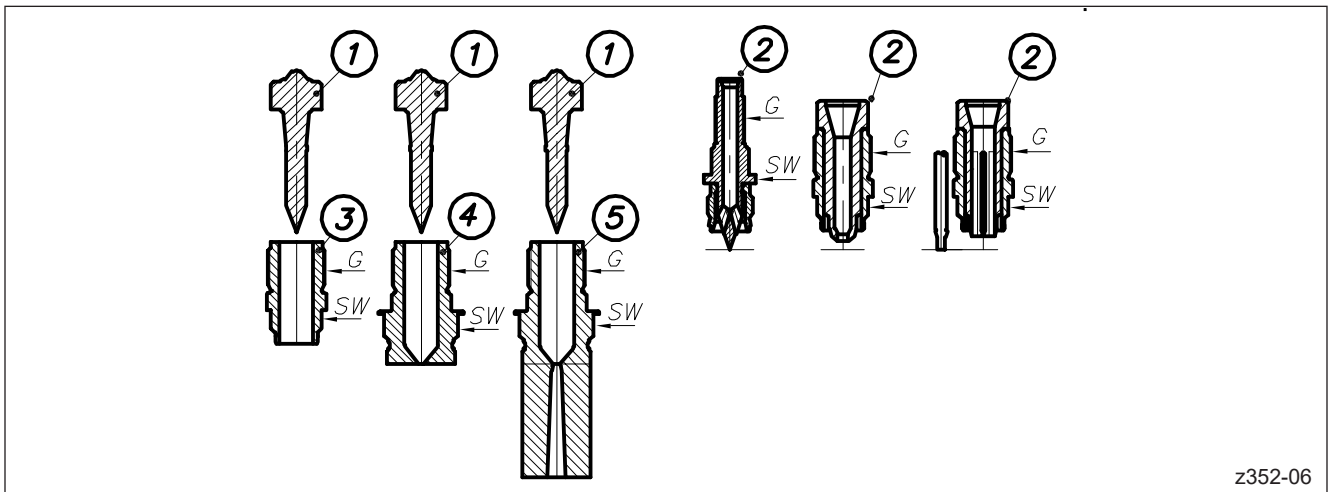

Picture 70: Examples of tip inserts

- 1 Tip insert
- 2 Tip insert including nosepiece (one-piece)
- 3 Nosepiece
- 4 Screw-on gate bush
- 5 Extended screw-on gate bush
- G Thread
- SW Width across flats

**NOTE!**

Please pay attention to the notes in chapter „5. Installation“.

The threads (G) of the tip inserts must be coated with high temperature installation paste (see chapter „5.3.1 Tools and operating materials“.

Installation temperature 220°C.

Non-standard tip inserts may require tightening torques which differ from the values given here. In case of doubt always contact EWIKON.

Flow channel Ø of nozzle	3 mm	4.5 mm	6 mm	9 mm	12 mm	18 mm
Thread G	M5x0.5	M7x0.5	M10x0.75	M13x0.75	M16x0.75	M24x1.0
Nosepiece	SW8	SW8	SW9	SW12	SW16	SW24
Screw-on gate bush	SW8	SW11	SW13	SW17	SW24	SW27
HPSIII-S	95158... 95159...	95218... 95219...	95258-V01... 95259-V01...	95308-V01... 95309-V01...	95408-V01... 95409-V01...	95538...
pro SHOT			9SO060F-V01 9SO060S-V01			
HPSIII-SXE	-	-	93259...	93309...	93409...	93539...
HPSIII-NVE	NV95158... NV95159...	NV95218... NV95219...	NV95258-V01... NV95259-V01...	NV95308-V01... NV95309-V01...	NV95408-V01... NV95309-V01...	NV95538...
pro SHOT VG			9SV060F-V01 9SV060S-V01			
HPSIII-NVI	-	-	EN306...L	EN309...L	EN312...L EN312...H	EN218...L EN218...H
HPSIII-L2X	-	-	95063....	95093....	95123....	95182....
HPSIII-L2X-NV	-	-	NV95063...	NV95093...	NV95123...	NV95182..
HPSIII-MV	95...-3 / 95...-4 93...-3	-	-	-	-	-
Tightening torque [Nm]	3.5	3.5	13	30	50	100
Tightening torque [ft·lb]	2.6	2.6	9.6	22.1	36.9	73.8

Chart 15: Tightening torques for tip inserts

9.4 Tightening torques for HPS III-L2X nozzles

Nozzle	Thread	Width across flats AW	Tightening torque Lubricated (high temperature installation paste, see chapter „5.3.1 Tools and operating materials“)	
			M _A [Nm]	M _A [ft·lb]
6 mm (Part No. 95063)	M18x1,5	22	50	36.88
9 mm (Part No. 95093)	M22x1,5	27	100	73.76
12 mm (Part No. 95123)	M30x1,5	32	200	147.51
18 mm (Part No. 95183)	M42x1,5	41	460	339.28

Chart 16: Tightening torques for HPS III-L2X nozzles (Part connecting nut / Nozzle)

**NOTE!**

The tightening torques given above are valid for an installation temperature of 200 °C.

9.5 Tightening torques for screws to fix the valve pin in the valve pin retainer

Valve pin diameter Ø [mm]	Thread (screw)	Tightening torque	
		M _A [Nm]	M _A [ft·lb]
1.5	M10x1	5	3.7
2	M8x1	4	3.0
	M10x1	5	3.7
	M12x1	7	5.2
3	M10x1	5	3.7
	M12x1	7	5.2
	M13x1	7	5.2
	M14x1	8	5.9
4	M14x1	8	5.9
	M18x1	11	8.1
5	M18x1	11	8.1
6	M18x1	11	8.1
	M19x1	12	8.9
8	M18x1	11	8.1
	M19x1	12	8.9

Chart 17: Tightening torques for screws to fix the valve pin in the valve pin retainer (pneumatic and hydraulic drive units)

- The tightening torques given above are only valid for unlubricated screws. All parts must be clean.
- If the screw has been tightened with the correct torque the valve pin in the valve pin retainer has a clearance of 0.02 mm and can be rotated by hand. Jamming of the valve pin must be avoided!

9.6 Tightening torques for drive units

For drive unit (Item number see drawing provided by EWIKON)	For item number (screw-in housing cover)	Thread	Tightening torque Lubricated (high temperature installation paste, see chapter „5.3.1 Tools and operating materials“)	
			M _A [Nm]	M _A [ft·lb]
16720, 19110, 19550	17699	M36x1.5	40	29.5
16818	16800	M42x1.5	45	33.2
17368	17336	M42x1.5	45	33.2
17930 (17933), 17218	17200	M56x1.5	60	44.3
17937, 17258, 19245	17250	M56x1.5	90	66.4
19551, 16700, 19111	19106	M56x1.5	60	44.3
19551-V01	19106-V01	M56x1.5	60	44.3
16740, 19112, 19552	19107	M70x1.5	100	73.8
19250	19251	M72x2.0	120	88.5
19720	19721	M28x1.5	25	18.4
19730, 19783-V01, 19784-V01, 19855, 22710	19731	M36x1.5	35	25.8
19700, 19705, 19739, 19756, 19757, 19765, 19766, 19780-V01	19701	M42x1.5	35	25.8
19755 (19750), 19710, 19758, 19767, 19781-V01, 19854	19711	M56x1.5	60	44.3
19740	19741	M56x1.5	90	66.4
Until 01/2013: 19759, 19760, 19768	19761	M72x2.0	110	81.1
From 01/2013: 19759, 19760, 19768, 19782-V01	19761	M70x1.5	85	62.7
19785-V01, 19770	19771	M56x1.5	90	66.4

Chart 18: Tightening torques for drive units

9.7 Tightening torques for valve pin retainer for electric drive units

Valve pin Ø [mm]	Thread (valve pin retainer)	Tightening torque	
		M _A [Nm]	M _A [ft·lb]
1.2	M10x1	10	7.4
2			
3	M14x1	15	11.0
4			

Chart 19: Tightening torques for valve pin retainer (electric drive units)

- The tightening torques given above are only valid for unlubricated screws. All parts must be clean.
- If the valve pin retainer has been tightened with the correct torque the valve pin in the valve pin has a clearance of 0.02 mm and can be rotated by hand. Jamming of the valve pin must be avoided!

9.8 Tightening torques for valve pin seals



CAUTION!

Replacement of valve pin seals

The replacement of valve pin seals may only be carried out from EWIKON trained and specialised staff! Otherwise it may come to leakage during operation and significant material damage.

9.8.1 Tightening torques for one-piece valve pin seals

Valve pin Ø [mm]	Item number	Thread (valve pin retainer)	Tightening torque Thread lubricated (high temperature installation paste, see chapter „5.3.1 Tools and operating materials“)	
			M _A [Nm]	M _A [ft·lb]
1.5	17235	M6x0.5	3.5	2.6
	19094			
1.5	19034	M8x0.75	7	5.2
	19093			
2	16980	M6x0.5	3.5	2.6
	16732			
	19095			
2	17969	M8x0.75	7	5.2
	19096			
3	17350	M8x0.75	7	5.2
	17353			
	16712			
	16929			
	19097			
	19098			
4	16752	M10x1	16	11.8
	17342			
	19099			
	19100			
5	17399	M12x1	25	18.4
6	17425	M16x1	45	33.2
8	17427	M18x1	65	47.9

Chart 20: Tightening torques for one-piece valve pin seals

9.8.2 Tightening torques for two-piece valve pin seals

Valve pin Ø [mm]	Sealing element item number	Pressure screw		Tightening torque Thread lubricated (high temperature installation paste, see chapter „5.3.1 Tools and operating materials“)	
		Item number	Thread	M _A [Nm]	M _A [ft·lb]
1.7	22550-SV01	22570 22571	M9x0.75	5.5	4
	22550-SV02				
	22550-SV03				
	22550-SV04				
2.2	22552-SV01	22570 22571	M9x0.75	5.5	4
	22552-SV02				
	22552-SV03				
	22552-SV04				
3.2	22554-SV01	22575 22576	M11x1	8	5.9
	22554-SV02				
	22554-SV03				
	22554-SV04				
4.2	22556-SV01	22580 22581	M13x1	13	9.6
	22556-SV02				
	22556-SV03				
	22556-SV04				
5.2	22558-SV01	22585	M15x1	25	18.5
	22558-SV02				
	22558-SV03				
	22558-SV04				
6.2	22560-SV01	22585	M15x1	23	17
	22560-SV02				
	22560-SV03				
	22560-SV04				

Chart 21: Tightening torques for two-piece valve pin seals

EWIKON
Heißkanalsysteme GmbH
Siegener Straße 35
35066 Frankenberg
Tel: +49 6451 / 501-0
Fax: +49 6451 / 501-202
E-Mail: info@ewikon.com
www.ewikon.com

Technical information subject to alteration..

EWIKON